



IRONCRAFT

2512 SERIES FLEX-WING ROTARY CUTTER



OPERATION AND PARTS MANUAL

Read and understand the manual. This manual provides information and procedures to safely operate and maintain the 2512 Series Flex-Wing Rotary Cutter.



Scan QR code for a digital version of this manual



June 2023

FIELD PROVEN ATTACHMENTS

EST



2014

IRONCRAFT

Forging Ahead
CRAFTED & MANUFACTURED

WWW.IRONCRAFTUSA.COM

Revised March 9, 2024
©2023 IronCraft Attachments. All rights reserved.

CONTENTS

INTRODUCTION	3
1.1 Welcome	3
1.2 Intended Use	3
1.3 Safe Operation	3
1.4 Safety Shields	4
1.5 Specifications	4
1.6 Intended Usage	5
1.7 Operator Orientation	5
1.8 Serial Number Location	5
1.9 Owner/Operator Manual Storage	5
1.10 Product Improvements	5
1.11 Disposal of Equipment	5
SAFETY SIGNS AND LABELS	6
2.1 General Safety	6
2.2 Safety Alert Symbols	7
2.3 Safety Icon Nomenclature	8
2.4 General Safety Instruction	9
2.5 Training	12
2.6 OSHA Training Requirements	12
2.7 Federal Laws & Regulations	13
2.8 Sign-Off Form	14
2.9 Operation Safety	15
2.10 Transporting Safety	15
2.11 Storage Safety	15
2.12 Maintenance Safety	15
SAFETY SIGNS AND LABELS	16
3.1 General Information	16
3.2 How to Install Replacement Safety Signs	16
3.3 Safety Sign Locations	17
3.3.1 Cutter Deck Safety Signs	18
NOMENCLATURE	19
ASSEMBLY	20
5.1 Tools Required	20
5.2 Assembly Procedure	20
5.2.1 Leveling the Center Deck	22
5.2.2 Leveling the Wing Decks	23
5.3 Installing the Driveline	24
5.4 Checking the Driveline Length	25
5.5 Shortening the Driveline	26
OPERATION	27
6.1 User Safety Training	27
6.2 Tractor Requirements	28
6.2.1 Equipment and Capabilities:	29
6.2.2 Tractor Safety Devices	29
6.2.3 ROPS and Seat Belt	29
6.2.4 Drawbar	30
6.2.5 Power Take-Off (PTO)	30
6.3 Attaching to Tractor	31
6.4 Setting the Rotary Cutter	32
6.4.1 Leveling Front-to-Back	33

6.4.2 Setting the Cutting Height	33
6.4.3 Wing Stop Adjustment	33
6.5 Initial Setup Checklist	34
6.7 Pre-Operation Checklist	35
6.8 General Operating Procedure	36
6.9 Chain Shielding	38
6.10 Right of Way (Roadway) Mowing	38
6.11 Detaching From Tractor	39
TRANSPORTING	41
7.1 Transporting Safety (Road)	41
7.2 Transporting Procedure	42
STORAGE	44
8.1 Storage Safety	44
8.2 Placing In Storage	44
8.3 Removing From Storage	45
SERVICE AND MAINTENANCE	45
9.1 Maintenance Safety	45
9.2 Welding Repairs	47
9.3 Greasing	48
9.4 Gearbox Lubrication	49
9.5 Driveline Lubrication	49
9.6 Blade Servicing	49
9.6.2 Blade Installation	50
9.6.3 Blade Sharpening	50
9.6.1 Blade Removal	50
9.7 Blade Carrier Removal	51
9.8 Blade Carrier Installation	51
9.9 Slip Clutch Operational Check	51
9.10 Slip Clutch Adjustment	52
9.11 Slip Clutch Disassembly/Assembly	53
9.12 Slip Clutch Run-In Procedure	53
9.13 Bolt Torque Requirements	54
9.14 Service Record	55
TROUBLESHOOTING	56
Limited Warranty	58
PARTS	59
12.1 A-Frame Components	60
12.2 Center Deck Components	62
12.3 Center Shield Components	64
12.4 Driveline & Shield Components	65
12.5 Wing Deck Components	66
12.6 Wheel Lift Components	68
12.7 Wheel Options	69
12.8 Hydraulic Components	70
12.9 Chain Guard Components	71
12.10 Comer 540/1000 RPM Splitter Gearbox Components	72
12.11 GTM 540/1000 RPM Splitter Gearbox Components	74
12.12 Outboard Gearbox Components	76
12.13 Center Deck Cross Shaft Components	78
12.14 C.V. Driveline Components	79
12.15 Wing Driveline Components	80

INTRODUCTION

1.1 WELCOME

Congratulations on your choice of a IronCraft flex-wing rotary cutter. This equipment has been designed and manufactured to meet the needs of discerning users. Many features incorporated into this rotary cutter are the result of suggestions made by customers like you.

Read this manual carefully to learn how to operate the rotary cutter safely and how to set it to provide maximum cutting efficiency. By following the operating instructions, in conjunction with a good maintenance program, your IronCraft rotary cutter will provide many years of trouble-free service.

1.2 INTENDED USE

The rotary cutter is designed for cutting weeds, grass, and brush up to 2" diameter. The cutter uses three spindles with two free-swinging blades each, which reduce the shock of impact when a stationary object is contacted. Slip clutches protect the gearboxes and driveline from damage. Standard equipment includes driveline shields, gearbox shields, and front and rear chain discharge shields.

1.3 SAFE OPERATION

Safe, efficient, and trouble-free operation of your rotary cutter requires that you, and anyone else who will be using or maintaining the unit, read and understand the information contained within the Owner's Manual. Use this manual for frequent reference and to pass on to new operators or owners.



WARNING **READ AND UNDERSTAND MANUAL.**



To prevent personal injury or even death, be sure you read and understand all of the instructions in this manual and other related OEM equipment manuals! The rotary cutter, if not used and maintained properly, can be dangerous to users unfamiliar with its operation. Do not allow operating, maintaining, adjusting, or cleaning of this rotary cutter until the user has read this manual and has developed a thorough understanding of the safety precautions and functions of the unit. This rotary cutter is designed for the specific purpose of cutting grass, weeds, and brush. **DO NOT** modify or use this rotary cutter for any application other than that for which it was designed. Rotary cutters maintained or operated improperly or by untrained personnel can be dangerous; exposing the user and/or bystanders to possible serious injury or death.

1.4 SAFETY SHIELDS

Some of the illustrations in this manual may show the equipment with safety shields removed for clarity. Never operate the rotary cutter unless all safety shields are in place.



WARNING

CUTTING OR ENTANGLEMENT HAZARD

Operating the rotary cutter without the safety shields could result in physical injury or death. Make sure all shields are properly installed before operating the rotary cutter. This equipment should never be operated with any safety shielding removed.



1.5 SPECIFICATIONS

		2512		
RECOMMENDED MINIMUM HP		35 HP (Gear Drive Transmission)	CUT WIDTH	144"
HITCH		Swivel Clevis	OVERALL WIDTH	151"
DECK THICKNESS		10 Gauge	OVERALL LENGTH W/ WHEELS	158"
DECK HEIGHT		11"	TONGUE WEIGHT	759 lbs
SIDE SKIRT MATERIAL		3/ 16"	OVERALL WEIGHT	2630 lbs
HINGE RODS		1"	CUT HEIGHT	1- 1/2" to 12"
OUTBOARD GEARBOX		75 HP	CUTTING CAPACITY	up to 2"
SPLITTER GEARBOX		175 HP	WHEEL TYPE	5 Lug Laminated Std. Used Airplane Optional
INPUT PTO		ASAE CATS Constant Velocity	SUSPENSION (SHOCK ABSORBER)	Single Spring
WING DRIVE PTO		ASAE CAT 4 with Slip Clutch	SKID SHOES	Replaceable
GEARBOX RPM		540	CHAIN SHIELDS	Single Row Chain Shields Standard
BLADES		1/ 2" x 3" with Lift	TOWING SAFETY CHAIN	Standard
BLADE TIP SPEED		15, 6 5 7 FPM	GEARBOX WARRANTY	5 Year Limited
BLADE OVERLAP		6"		
BLADE CARRIER		3/ 16" Formed Plate with 3/ 4" x 6" Bar		

Specifications subject to change without notice.

1.6 INTENDED USAGE

Do not use this rotary cutter for any other purpose than its intended use of cutting grass, weeds, and brush.

1.7 OPERATOR ORIENTATION

The directions left, right, front, and rear, as mentioned throughout this manual, are as seen from the tractor operator's seat and facing in the direction of travel.

1.8 SERIAL NUMBER LOCATION

The serial number decal is located on the left front of the center deck. Record the serial number in the space provided for easy reference when contacting IronCraft with questions.

Serial No. _____



1.9 OWNER/OPERATOR MANUAL STORAGE

Store the Owner/Operator manual and other operating materials in the document storage tube located on the splitter gearbox shield.



1.10 PRODUCT IMPROVEMENTS

Because IronCraft maintains an ongoing program of product improvement, we reserve the right to make improvements in design or changes in specifications without incurring any obligation to install them on units previously sold.

1.11 DISPOSAL OF EQUIPMENT

The IronCraft rotary cutter has been designed for the specific purpose of cutting grass, weeds, and brush. When this unit is no longer capable of doing its designed purpose, it should be dismantled and scrapped. Do not use any materials or components from this unit for any other purpose.

SAFETY SIGNS AND LABELS

2.1 GENERAL SAFETY

Safety of the operator and bystanders is one of the main concerns in designing and developing a new piece of equipment. Designers and manufacturers build in as many safety features as possible. However, every year many accidents occur which could have been avoided by a few seconds of thought and a more careful approach to handling the equipment.

Most work-related accidents are caused by failure to observe basic safety rules or precautions. An accident can often be avoided by recognizing potentially hazardous situations before an accident occurs. As you assemble, operate, or maintain the rotary cutter (unit), you must be alert to potential hazards. You should also have the necessary training, skills, and tools to perform any assembly or maintenance procedures.

Improper operation and maintenance of this unit could result in a dangerous situation that could cause injury or death.

If you have any questions not answered in this manual or require additional copies or the manual is damaged, please contact your dealer or:

IronCraft Attachments

7 Rocky Mt Rd, Athens, Tennessee 37303

Phone: (423) 405-5150 Fax: (423) 405-5904

The manual is also available for download at: www.ironcraftusa.com

IronCraft cannot anticipate every possible circumstance that might involve a potential hazard. The warnings in this manual and on the unit are, therefore, not all-inclusive. If a method of assembly, operation, or maintenance not specifically recommended by us is used, you must satisfy yourself that it is safe for you and for others. You should also ensure that the unit will not be damaged or be made unsafe by the methods that you choose. The information, specifications, and illustrations in this manual are based on the information that was available at the time this material was written and can change at any time without notice.



WARNING

Do not assemble, operate, or maintain the unit until you read and understand the information contained in this manual.



Safety precautions and warnings are provided in this manual and on the unit. If these hazard warnings are not heeded, bodily injury or death could occur to you or to other persons.

2.2 SAFETY ALERT SYMBOLS



This is the safety alert symbol and will be accompanied with a descriptive pictorial. It is used to alert you to potential personal injury hazards. Obey all safety messages that follow this symbol to avoid possible injury or death.

This manual contains DANGERS, SAFETY INSTRUCTIONS, CAUTIONS, IMPORTANT NOTICES, and NOTES which must be followed to prevent the possibility of improper service, damage to the equipment, personal injury, or death. The following key words call the readers' attention to potential hazards. Hazards are identified by the "Safety Alert Symbol" and followed by a signal word such as "DANGER", "WARNING", or "CAUTION".



DANGER

Indicates an imminently hazardous situation which, if not avoided, will result in death or serious injury. This signal word is limited to the most extreme situations.



WARNING

Indicates a potentially hazardous situation which, if not avoided, could result in death or serious injury.



CAUTION

Indicates a potentially hazardous situation which, if not avoided, may result in minor or moderate injury.

NOTICE

Indicates that equipment or property damage can result if instructions are not followed.

SAFETY INSTRUCTIONS

Safety instructions (or equivalent) signs indicate specific safety-related instructions or procedures.

Note: Contains additional information important to a procedure.

2.3 SAFETY ICON NOMENCLATURE

Pictorial icons signal a type of hazard and warn of personal protection issues, prohibited actions, and hazard avoidance.

PERSONAL PROTECTION / IMPORTANT INFORMATION







-  Read the manual
-  Damaged hazard label
-  Eye protection
-  Fire extinguisher
-  First aid kit
-  Hand protection
-  Head protection
-  Hearing protection
-  OEM parts only
-  Protective shoes
-  Remove key
-  Set parking brake
-  Stop engine
-  Think safety
-  Transmission in park
-  Use proper support
-  Use proper tools
-  Visibility

-  Rollover protection
-  Wear seat belt
-  Weight rating
-  Clear vision

PROHIBITED ACTIONS

-  Do not alter or modify
-  Do not leave out tools
-  Do not weld
-  No alcohol
-  No drugs
-  No smoking
-  No young children
-  No riders

HAZARD AVOIDANCE

-    Crush hazard
-  Crush hazard (chock wheels)
-  Crush hazard (foot)
-  Defective or broken part
-  Entanglement hazard

-  Explosive separation hazard
-  Fire hazard
-  Cutter blade contact hazard (hand)
-  Cutter blade contact hazard (foot)
-  Pinch point hazard
-  Projectile hazard
-  Rollover protection
-  Safety alert symbol
-  Safety shields
-  Sharp object hazard
-  Slipping injury
-  Stay clear
-  Zero pressure
-  Tripping injury
-  High-pressure fluid hazard
-  Hose damage
-  Falling hazard
-  Crush hazard
-  Pressure hazard

2.4 GENERAL SAFETY INSTRUCTION

The owner/operator is responsible for the safe use and maintenance of the rotary cutter. Make sure anyone who is operating, maintaining, or working around the rotary cutter is familiar with the operating and maintenance procedures and related safety information contained in this manual. This manual will take you step-by-step through your working day and alerts you to all good safety practices that should be used while using the rotary cutter.

In addition to the design features of the rotary cutter, including safety signs, accident prevention is dependent upon the awareness, concern, prudence, and proper training of the people involved in the operation, maintenance, and storage of the rotary cutter.

These general safety instructions apply to the overall use and maintenance of the rotary cutter. In addition to this safety section, refer also to safety messages and instructions in each of the appropriate sections of this manual. More specific instructions on safety are found in the operation, transporting, maintenance, and storage sections of this manual. Refer to these sections before performing any of these tasks.



DANGER

Failure to comply with the following safety instructions will result in death or serious injury.



CRUSH HAZARD

Driveline separation or PTO stub shaft failure can cause serious injury or death. Make sure drivelines and driveline shields are the correct length and correctly installed.



ENTANGLEMENT HAZARD

Failure to maintain shields and deflectors may result in serious injury or death from entanglement.



CRUSH HAZARD

Hydraulic or mechanical failure can allow a wing to drop suddenly without warning. Do not allow anyone to walk under or stand near a raised wing.



WARNING

Failure to comply with the following safety instructions could result in serious injury and possibly even death if they are not understood and followed.



PROVIDE USER WITH LITERATURE

IronCraft rotary cutter owners must provide operator instructions to anyone using the rotary cutter before use, and at least annually thereafter. Refer to “2.6 OSHA Training Requirements” on page 14.



WARNING

Failure to comply with the following safety instructions could result in serious injury and possibly even death if they are not understood and followed.



STAY CLEAR

Clear the area of people, especially small children, before using the rotary cutter. Under no circumstances should young children be allowed to work with or around the rotary cutter.



IMPAIRED USER HAZARD

Do not attempt to assemble, operate, or maintain this rotary cutter under the influence of drugs or alcohol. Consult your doctor before using this rotary cutter while taking prescription medications.



CRUSH HAZARD

Do not allow anyone to ride on the tractor or the rotary cutter. Falling or crushing hazards could result in severe injuries or death.



FALLING HAZARD

Do not allow riders on the hitch, tractor, or rotary cutter at any time. Falling could result in severe injuries or death.



NO UNAUTHORIZED MODIFICATIONS

Do not modify the rotary cutter or safety devices. Do not weld on the unit. Unauthorized modifications may impair its function and safety. Personal injury or death could result from unauthorized modifications. If the rotary cutter has been altered in any way from the original design, IronCraft does not accept any liability for injury or warranty.



DAMAGED PARTS HAZARD

Do not use the rotary cutter if any parts are damaged. If the rotary cutter has a defect, immediately stop using it and remedy the problem before continuing.



THROWN OBJECTS HAZARD

Rotary cutter can throw objects up to 300 feet. To avoid serious injury or death: Keep all thrown object shielding in place. Inspect the area for potential thrown objects before cutting. Do not operate the rotary cutter with the deck or wings raised.



IMPROPER USE HAZARD

Do not use the cutter to lift or carry objects, tow other equipment, pull fence posts, stumps, or other objects, or for any other purpose than its intended use of cutting grass, weeds, and brush. Using the cutter for unintended purposes can cause serious bodily injury or death.



CAUTION

The following safety instructions are provided to help prevent potential injury. Not following these instructions may lead to injury.

PERSONAL PROTECTION EQUIPMENT

When using this rotary cutter, wear appropriate personal protective equipment. This list may include, but is not limited to:



- Protective shoes with slip-resistant soles
- Protective goggles, glasses, or a face shield
- Protective clothing and gloves
- Safety vest (when operating near roads)
- Hearing protection



HEARING LOSS

Prolonged exposure to loud noise may cause permanent hearing loss. Working environments with noise-producing equipment can cause partial to permanent hearing loss. We recommend using hearing protection anytime noise levels exceed 80 decibels (dB). Noise levels over 85 dB, on a long-term basis, can cause severe hearing loss. Noise levels over 90 dB over a period of time can cause permanent and even total hearing loss. Hearing loss from loud noise is cumulative over a lifetime without hope of natural recovery.



CRUSH HAZARD

The tractor should be equipped with a Roll Over Protective Structure (ROPS) and a seat belt. A crushing hazard may occur if the driver is ejected from the seat while the tractor is in motion. Fasten the seat belt whenever the tractor is moving.

SAFETY INSTRUCTIONS

The following safety instructions are provided to help prevent injury or limit equipment damage.



SAFETY SIGNS

Replace any missing or hard-to-read safety signs or instructional labels. Use care when washing or cleaning the rotary cutter. Replacement safety sign locations and part numbers are provided in this manual and are available from an authorized dealer parts department or the factory.



FIRST AID KIT

Have a first aid kit available for use should the need arise and know how to use it.



FIRE EXTINGUISHER

Have a fire extinguisher available for use should the need arise and know how to use it.

THINK SAFETY! WORK SAFELY!

2.5 TRAINING

Anyone who will be using and/or maintaining the rotary cutter must read, clearly understand, and follow ALL safety, operation, and maintenance information presented in this manual, other related OEM manuals, and the safety signs.

If you do not understand any information in this manual, see your dealer or contact IronCraft before proceeding. Do not use or allow anyone else to use this rotary cutter until all information has been reviewed. Annually review this manual before the season start-up.

Make periodic reviews of SAFETY and OPERATION of the rotary cutter a standard practice. An untrained operator is not qualified to use this rotary cutter.

2.6 OSHA TRAINING REQUIREMENTS

The following training requirements have been taken from Title 29, Code of Federal Regulations Part 1928.57(a)(6). www.osha.gov.

Operator Instructions: At the time of initial assignment and at least annually thereafter, the employer shall instruct every employee who operates an agricultural tractor and implements in the safe operating practices and servicing of equipment with which they are or will be involved, and of any other practices dictated by the work environment.

2.7 FEDERAL LAWS & REGULATIONS

IMPORTANT FEDERAL LAWS AND REGULATIONS CONCERNING EMPLOYERS, EMPLOYEES, AND OPERATORS

This section is intended to explain in broad terms the concept and effect of the following federal laws and regulations. It is not intended as a legal interpretation of the laws and should not be considered as such.

U.S. PUBLIC LAW 91-596 (The Williams-Steiger Occupational Safety and Health Act of 1970) OSHA

This Act Seeks:

“ ... to assure so far as possible every working man and woman in the nation safe and healthful working conditions and to preserve our human resources...”

DUTIES

Sec. 5(a) Each Employer -

(1) shall furnish to each of its employees employment and a place of employment which are free from recognized hazards that are causing or are likely to cause death or serious physical harm to its employees.

(2) shall comply with occupational safety and health standards promulgated under this Act.

(b) Each employee shall comply with occupational safety and health standards and all rules, regulations, and orders issued pursuant to this Act which are applicable to his or her own actions and conduct.

OSHA Regulations

Current OSHA regulations state in part: “At the time of initial assignment and at least annually thereafter, the employer shall instruct every employee in the safe operation and servicing of all equipment with which the employee is, or will be involved.” These will include (but are not limited to) instructions to:

Keep all guards in place when the machine is in operation;

Permit no riders on equipment;

Stop engine, disconnect the power source, and wait for all machine movement to stop before servicing, adjusting, cleaning, or unclogging the equipment, except where the machine must be running to be properly serviced or maintained, in which case the employer shall instruct employees as to all steps and procedures which are necessary to safely service or maintain equipment.

Make sure no one is within 300 feet of machinery before starting the engine, engaging power, or operating the machine.

EMPLOYEE TRACTOR OPERATING INSTRUCTIONS:

1. Securely fasten your seat belt if the tractor has a ROPS.
2. Where possible, avoid operating the tractor near ditches, embankments, and holes.
3. Reduce speed when turning, crossing slopes, and on rough, slick, or muddy surfaces.
4. Stay off slopes too steep for safe operation.
5. Watch where you are going, especially at row ends, on roads, and around trees.
6. Do not permit others to ride.
7. Operate the tractor smoothly - no jerky turns, starts, or stops.
8. Hitch only to the drawbar and hitch points recommended by tractor manufacturers.
9. When tractor is stopped, set brakes securely and use park lock if available.

Child Labor Under 16 Years Old

Some regulations specify that no one under the age of 16 may operate power machinery. It is your responsibility to know what these regulations are in your own area or situation. (Refer to U.S. Dept. of Labor, Employment Standard Administration, Wage & Home Division, Child Labor Bulletin # 102).

2.9 OPERATION SAFETY

Refer to “ 6.1 User Safety Training” on page 29 for safety recommendations related to using the rotary cutter. All applicable safety recommendations in other sections should also be followed.

2.10 TRANSPORTING SAFETY

Refer to “ 7.1 Transporting Safety (Road)” on page 43 for safety recommendations related to transporting the rotary cutter. All applicable safety recommendations in other sections should also be followed.

2.11 STORAGE SAFETY

Refer to “ 8.1 Storage Safety” on page 46 for safety recommendations related to storing the rotary cutter. All applicable safety recommendations in other sections should also be followed.

2.12 MAINTENANCE SAFETY

Refer to “ 9.1 Maintenance Safety” on page 47 for safety recommendations related to maintaining the rotary cutter. All applicable safety recommendations in other sections should also be followed.

SAFETY SIGNS AND LABELS

3.1 GENERAL INFORMATION

The types of safety signs (hazard labels) and instructional labels, along with their locations on the equipment, are shown in the following illustrations. Good safety practices require that you familiarize yourself with the various safety signs, the type of warning, and the area or particular operation related to that area that requires your SAFETY AWARENESS.

THINK SAFETY! WORK SAFELY!

Pay close attention to the safety signs and instructional labels attached to the tractor and the rotary cutter. Duplicate safety signs, which are attached to the rotary cutter, can also be found in this section. If the rotary cutter is missing a label or one is unreadable, replace the label before using the rotary cutter.

SAFETY INSTRUCTIONS

The following safety instructions are provided to help prevent injury or limit equipment damage.



SAFETY SIGNS AND INSTRUCTIONAL LABELS

1. Keep safety signs or instructional labels clean and legible at all times. Use a clean, damp cloth to clean safety decals.
2. Replace any missing or hard-to-read safety signs or instructional labels.
3. Use care when washing or cleaning the equipment not to remove or damage the labels. When using a pressure washer to clean the rotary cutter, avoid spraying too close to decals; high-pressure water can enter through very small scratches or under edges of decals causing them to peel or come off.
4. Locations for the labels and replacement part numbers are shown in this section.
5. Replacement parts must have replacement labels attached during installation and/or before the rotary cutter is used.
6. Labels are available from your authorized dealer or from IronCraft at no charge.

3.2 HOW TO INSTALL REPLACEMENT SAFETY SIGNS

1. Clean and dry the installation area.

Note: Do not install the signs if the temperature is below 50°F.

2. Determine the exact position before you remove the backing paper.
 3. Remove the backing paper.
 4. Align the sign over the specified area and carefully press the sign to the part/frame.
-

Note: Small air pockets can be pierced with a pin and smoothed out using remaining backing paper.

3.3 SAFETY SIGN LOCATIONS

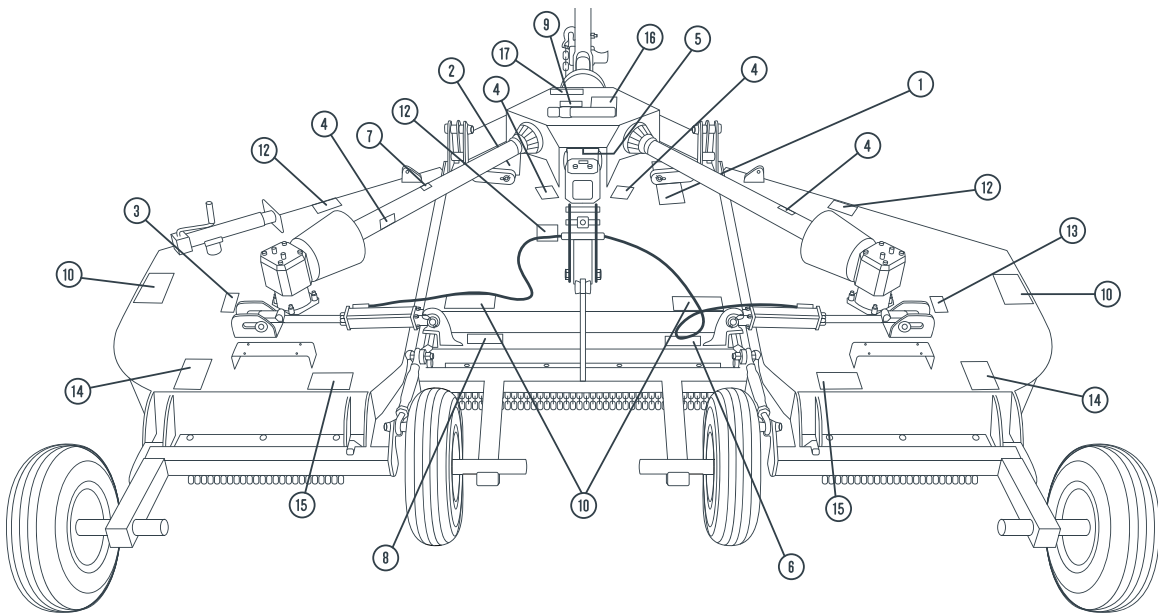

ITEM	TYPE	DESCRIPTION	QTY.
1	DANGER	Follow Safety Messages	1
2	DANGER	Maintain Shields and Deflectors	1
3	INSTRUCTIONAL	Blade Rotation (CCW)	1
4	DANGER	Rotating Driveline, Keep Away, Outer Shield Tube	2
5	DANGER	Shield Missing, Do Not Operate	1
6	WARNING	Use Paper or Cardboard to Check for Leaks	1
7	WARNING	PTO Speed 540 RPM	1
8	DANGER	Read the Manual (Spanish)	1
9	WARNING	Keep Mower Deck Clear of Debris	1
10	WARNING	No Riders	4
11	SERIAL	Serial Number	1
12	INSTRUCTIONAL	Made In the USA	3
13	INSTRUCTIONAL	Blade Rotation (CW)	1
14	DANGER	Keep Away - Thrown Objects	2
15	DANGER	Stay Clear	2
16	WARNING	Do Not Transport at Speeds Over 20 MPH	1
17	INSTRUCTIONAL	5 Year Gearbox Limited Warranty	1

3.3.1 CUTTER DECK SAFETY SIGNS

- 1. DANGER**

1. Make certain drivelines are of the correct length and security attached, DRIVELINE SEPARATION and/or PTO SHAFT FAILURE can cause INJURY or DEATH. (See Operator's Manual for procedure).

2. Make certain that driveline shields are **INSTALLED CORRECTLY** and **TURN FREELY** to prevent injury or death from entanglement.

3. Make certain that driveline is installed correctly on TRACTOR PTO SHAFT. Move your hand and foot until locking collar clicks forward and locks your hand in place.

4. Add PTO RPM unless specifically marked otherwise.
- 2. DANGER**

FAILURE TO FOLLOW SAFETY MESSAGES AND OPERATING INSTRUCTIONS CAN CAUSE SERIOUS BODILY INJURY OR EVEN DEATH TO OPERATOR AND OTHERS IN THE AREA.

1. Stay out of unsecured operator's controls, safety signs and instructional books for mowers and implement to prevent vision, shock, and accidents. Lock down any engine starting in an emergency. Do not drink and operate.

2. Use caution on wet or uneven ground, slopes, or uneven terrain or roadways. Risk of slip cause serious injury or death from being pitched or tripped over or other similar falling blades.

3. Operate only with tractor having Roll-Over Protection Structure (ROPS) and seat belt fastened correctly and buckled to prevent injury and possible death from ROPS or tractor rollover. Personal Protective Equipment (PPE) such as eye protection, hearing protection, and fire protection is also required.

4. Back up as support related machine and all PTO components should be pulled back to feet under or working underneath any PTO that is engaged or disengaged. Do not operate with PTO engaged unless you are in the area where possibility of injury or death from objects thrown by blades or other debris is not possible. See Operator's Manual.

5. Never transport or tow a mower or implement on a highway. Secure by required for transport by holding Operator Steps or Transport the on a highway (do not use tractor jack and lifting transport units on lifting implements).

6. Check Safety Check to make sure they are not missing. See Operator's Manual.

7. Make certain that PTO sign, Warning Lights, and Indicators are clearly visible. Follow local traffic codes.

8. Never operate with PTO engaged (especially, mowers) or with any of the areas where possibility of injury or death from objects thrown by blades or other debris is not possible.

9. Operate equipment under load in transport position at lower speed.

10. All tractor or gear or set work, change PTO, stop engine, and remove key, and wait until cooler of rotation has ceased to prevent equipment from starting again when you return to work.

11. Never repair or maintain a moving blade. Choking from cover the same injury or death.
- 3. DANGER**

FAILURE TO USE AND MAINTAIN SHIELDS AND DEFLECTORS IN GOOD CONDITION MAY LEAD TO INJURY OR DEATH FROM ENTAILMENT WITH ROTATING PARTS, BEING HIT BY OBJECTS THROWN WITH GREAT FORCE BY BLADES, OR BY BLADE CONTACT.

• Always replace Guards which have been removed for maintenance. Never operate with Guards missing or broken.

• Chain Guards, Gearbox & Driveline Shields, Rubber-Fabric Deflectors, and Solid Band Enclosures are subject to wear and lost or broken parts must be repaired or replaced as soon as damage is found.

• Safety Shielding must be installed and in good condition to reduce the possibility of thrown objects any time this machine is operated in any area where thrown objects could cause property damage or bodily injury.
- 4. BLADE ROTATION**
- 5. DANGER**

ROTATING DRIVELINE CONTACT CAN CAUSE DEATH KEEP AWAY!

DO NOT OPERATE WITHOUT

 - All driveline guards, tractor and equipment shields in place
 - Drivelines securely attached at both ends.
 - Driveline guards that turn freely on driveline
- 6. WARNING**

Use paper or cardboard to check for leaks. NEVER USE YOUR HAND. If oil penetrates skin, gangrene or other serious injury could occur. GET IMMEDIATE MEDICAL ATTENTION. See Operator's manual.
- 7. WARNING**

OPERATE THIS MACHINE AT **540 RPM**

TRACTOR PTO SPEED ONLY

Overspeeding PTO may cause component failure with resulting injury.
- 8. PELIGRO**

Si No Lee Ingles, Pida Ayuda a Alguien Que si Lo Lea Para Que le Traduzca las Medidas de Seguridad.
- 9. WARNING**

Keep Mower Deck Clear of Debris

There is a risk of Fire when dry material accumulates and contacts heat generated from rotating components. See Operator's Manual for fire prevention.
- 10. WARNING**

NO RIDERS
- 11. Serial Number**

0010001
- 12. MADE IN THE USA**

WITH U.S. & IMPORTED PARTS
- 13. BLADE ROTATION**
- 14. DANGER**

KEEP AWAY - THROWN OBJECTS

 - Inspect the area before mowing for potential mower hazards. Remove or avoid all foreign objects such as wire, cable, metal objects, and all other foreign material.
 - Foreign material can be thrown from the mower and cause serious bodily injury to the operator and passersby.
 - Do not let rotating blades contact solid objects like rocks, posts, curbs or guard rails.
 - Operate only if all Guards-Deflectors are in place and in good condition.
 - Do not operate with Mower or Wing raised off the ground.
 - Stop mowing if Passersby enter the area of thrown objects. (See Operator's Manual)
 - Stay away from rotating blades. Keep hands and feet away from rotating blades.
 - Do not approach mower until motion has stopped.
- 15. DANGER**

 - Stay clear when removing transport strap and lowering or raising wing.
 - Component failure or accidental operation of controls may allow wings to fall suddenly and cause SERIOUS INJURY or DEATH.
 - Operation with lift restrictions disabled must be fitted with oil for wings to lower slowly and safely.
 - Lock wings up securely for transporting.
 - Do not operate mower with wings raised when passersby are in the area.
 - Contact with Exposed Rotating Blades and/or being hit by thrown objects may cause INJURY or DEATH.
- 17. 5 YEAR GEARBOX LIMITED WARRANTY**
- 16. NOTICE TO OWNER**

An OPERATOR'S MANUAL, with Required Parts Listings, and a WARRANTY REGISTRATION CARD were attached to the implement at the time of purchase of the tractor. If they were not attached at the time of purchase, please contact your selling dealer at once.

 1. Read and understand Manual before operating the implement.
 2. Complete, sign and mail the Warranty Registration Card in today.

IMPORTANT

REQUIRED FOR JACK SHAFT UNIT SUGGESTED FOR STANDARD SHAFT

WARNING

 1. DO NOT transport at speeds above 20 mph. Exceeding 20 mph decreases braking safety and may cause loss of control and serious personal injury.
 2. ONLY transport behind a properly used and equipped tractor. NEVER tow behind a truck or other motor vehicle. ALWAYS properly fasten the implement safety tow chain to the tractor.
 3. Reduce speed on inclines, while turning, and when towing in adverse conditions.
 4. ENSURE a BRAKING system can be clearly seen from behind the unit. Turn ON the tractor's braking warning lights when transporting.

(Signs portrayed for reference, not to scale)

NOMENCLATURE

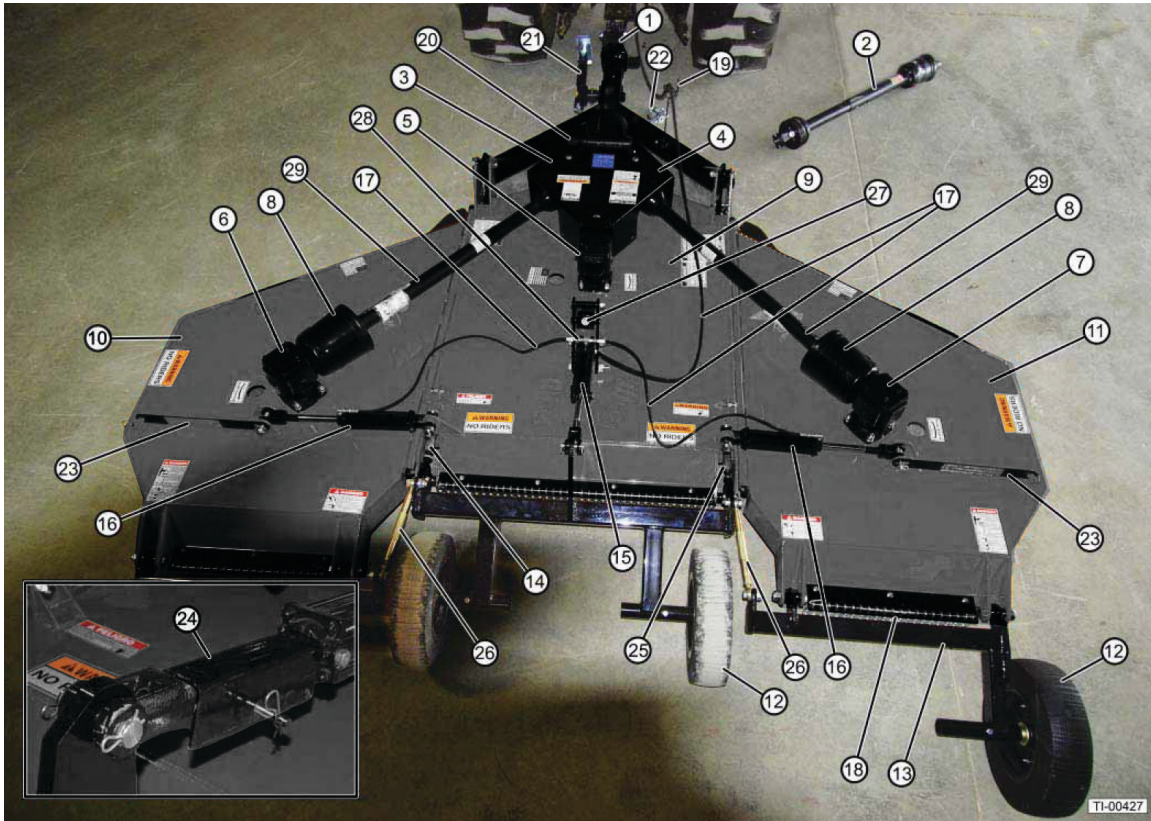

ITEM	DESCRIPTION
1	Swivel Hitch
2	Center Driveline
3	Splitter Gearbox
4	Splitter Gearbox Shield
5	Center Outboard Gearbox
6	Left Outboard Gearbox
7	Right Outboard Gearbox
8	Outboard Gearbox Shield
9	Center Deck
10	Left Wing Deck
11	Right Wing Deck
12	Tailwheel
13	Tailwheel Tube
14	Leveling Rods

15	Lift Hydraulic Cylinder
16	Wing Fold Hydraulic Cylinder
17	Hydraulic Hoses
18	Chain Shielding
19	Hydraulic Hose Holder
20	Document Storage Tube
21	Jack
22	Safety Chain
23	Wing Fold Lock Bar
24	Lift Cylinder Transport Lock
25	Leveling Rod Adjuster
26	Wing Leveling Turnbuckle
27	Suspension Spring Assembly
28	Hydraulic Tee
29	Wing Driveline

ASSEMBLY

5.1 TOOLS REQUIRED

TOOLS REQUIRED
Wrenches, 1/2", 5/8", 3/4", 1-1/8", 1-3/8", 1-1/2"
Ratchet with extension and sockets as above

5.2 ASSEMBLY PROCEDURE



WARNING CRUSH HAZARD



The weight of the hitch can cause serious injury or death if it falls on a person. Do not allow anyone to walk under or stand near the hitch when it is supported by a lifting device.

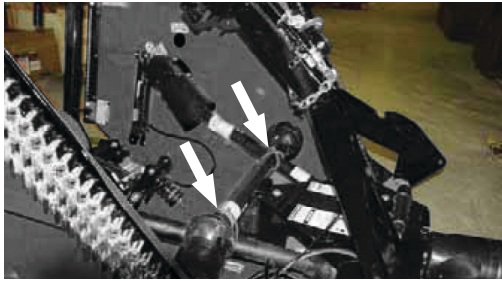

1. Cut the wires holding the center driveline to the cutter. Set the driveline aside for now.

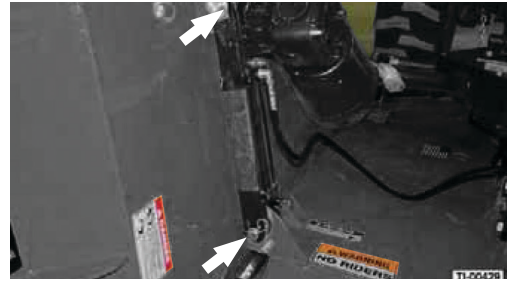

2. Verify that the wing locks and their retaining pins are in place.

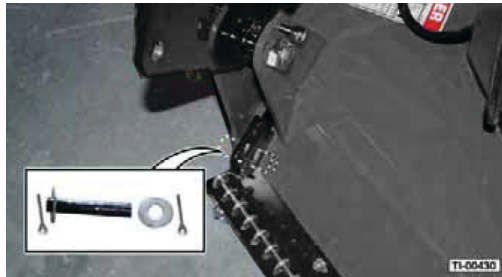

3. Remove the pin, washers, and cotter pins from the front of both leveling rods.

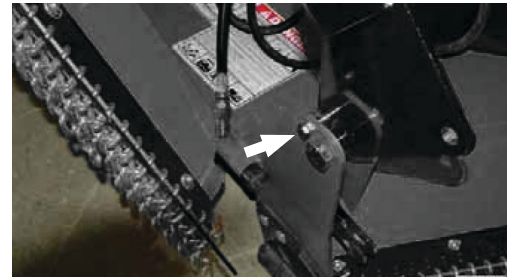

4. Remove and discard the bolts holding the hitch in its shipping position.

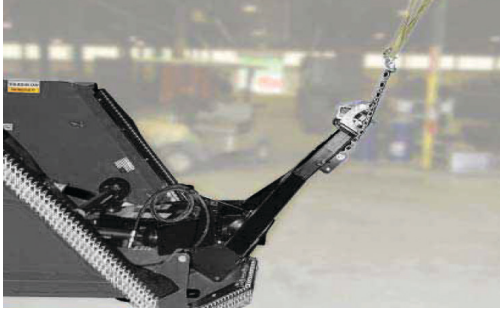

5. Rotate the hitch forward using a suitable lifting device. The lifting device may be attached to the safety chain.
7. Use the jack to adjust the hitch to the height of the tractor drawbar.
6. Remove the jack from its storage location on the left wing and install it on the lug on the left side of the hitch.
8. Board the tractor and start the engine. Back the tractor up to the cutter hitch until the holes in the drawbar and clevis are aligned.



CRUSH HAZARD

Crush hazard between hitch and implement. Do not allow anyone to stand between the hitch and implement during hook-up operations.

9. Turn off the tractor engine and dismount.
10. Insert a high strength drawbar pin through the clevis and drawbar holes and install retaining pin. Do not use a homemade or shop made pin.



CRUSH HAZARD

Unexpected separation of the cutter from the tractor can cause death or serious injury. Use only an OEM high-strength drawbar pin. Do not use a homemade or shop-made pin.

11. Route the hydraulic hose through the hose rack and attach to the tractor's hydraulic port.
12. Board the tractor and start the engine. Place the tractor gear selector in park or set the parking brake.

Note: Quick disconnect hydraulic couplers are not supplied with the unit. If desired, these may be procured from a local equipment dealer.



NOTICE

Disconnect the cylinders from the wings. Failure to do so will cause permanent damage.

13. Cycle the wheel lift cylinder several times to purge any trapped air and charge the hydraulic cylinder.
14. Raise the cutter fully and remove the transport lock from the lift cylinder.

15. Lower the cutter to the ground, set the parking brake, shut off the tractor, and remove the key.
16. Align the hole in the hitch with the hole in the front of the leveling rod, and install the pin, washers, and cotter pins previously removed in Step 3. Repeat for the other leveling rod.

Note: If necessary, lengthen the leveling rods by turning the adjustment at the rear of the rods. This will increase the clearance between the leveling rod pin and the hitch pivot bracket.

17. Adjust the leveling rods to have equal amounts of tension. This will be a starting point for a later leveling adjustment.

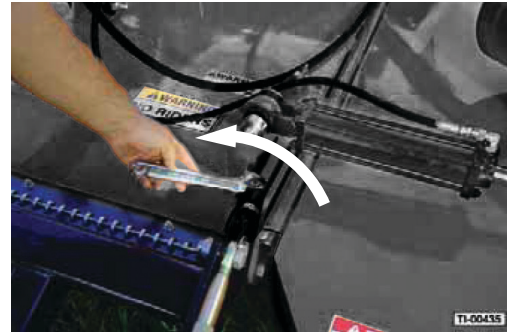

5.2.1 LEVELING THE CENTER DECK

1. Board the tractor and start the engine. Place the tractor gear selector in park or set the parking brake.
2. Use the hydraulics to adjust the cutter height until the front of the skid shoes are two to three inches off the ground.
3. Shorten or lengthen the leveling rods, as needed, until the front of the deck is 3/4" lower than the rear of the deck. Lengthening the leveling rods raises the back of the cutter.
4. Make sure the leveling rods have equal amounts of tension, and tighten the adjuster jam nuts.

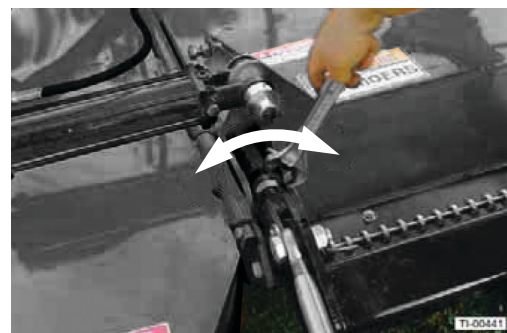
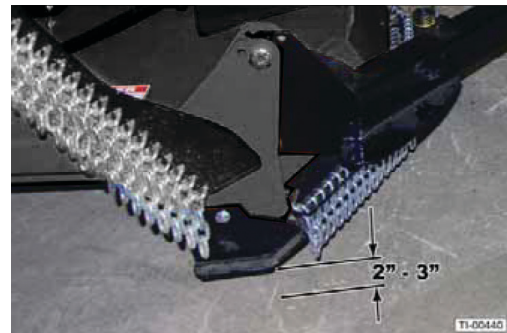

CRUSH HAZARD

The weight of the cutter can cause serious injury. Stay clear of the deck when it is raised off the ground.

5.2.2 LEVELING THE WING DECKS

Each wing section will need adjusting if the wing top is not level with the center deck top when the wings are unfolded. The wing lift hydraulic cylinders are not charged when the cutter is shipped, and must be filled with hydraulic oil before removing the wing locks. The wing lift cylinders must be disconnected from the wing first, charged second, reconnected with the wings, and then the wing locks can be removed.

1. Start the tractor and hold the lift control lever in the raised position until the hydraulic cylinders fully retract.
2. Place the control lever in the float position and repeat the process.
3. Block the wing to prevent it from falling in case air is present in the hydraulic system.



WARNING UNEXPECTED MOVEMENT



The cutter is shipped with the wings locked in the upright position. If the wing locks are not in place, the wings may free-fall due to air in the hydraulic system. To avoid death or serious injury from being struck by a wing, stay clear of the wings. Purge all air from the hydraulic system, and do not remove the wing locks until necessary to do so.



CRUSH HAZARD

Hydraulic or mechanical failure can allow a wing to drop suddenly without warning. Do not allow anyone to walk under or stand near a raised wing when the locks are removed.

4. Ensure the wings are entirely supported by the cylinders, and there is no tension on the wing lock bars. Remove the wing lock bars from the cylinder pins, rotate them onto the storage lugs, and secure with the retainer hairpins.

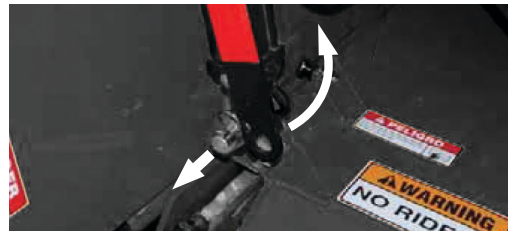

Note: It is normal for the wings to lower or raise at different rates.

5. Remove the blocking and lower the wings to their operating position
6. Check the tractor's hydraulic fluid reservoir and fill if necessary.



NOTICE

The cutter does not have a hydraulic reservoir and therefore can deplete the oil in the tractor's reservoir during the initial charging of the cylinders. After this initial setup, with the cutter and wings fully lowered, check the tractor's hydraulic oil reservoir and add oil as necessary.

7. Check the wing tops to see if they are level with the top of the center deck. If the outer edge of either wing top is higher or lower than the center deck, then that wing should be leveled as follows:
 - a. If the outer wing edge is higher than the center deck, loosen jam nut (1) and rotate turnbuckle (2) counterclockwise to lower the outer wing edge until the wing is level. Retighten jam nut when level.
 - b. If the outer wing edge is lower than the center deck, loosen jam nut (1) and rotate turnbuckle (2) clockwise to raise the outer wing edge until the wing is level. Tighten jam nut (1) to the correct torque when level.

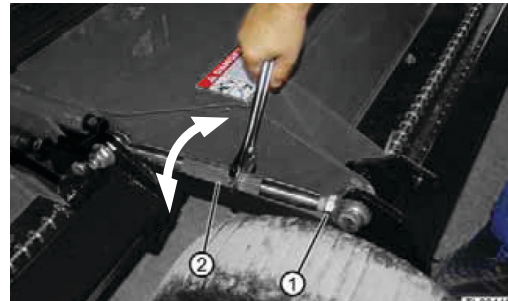

5.3 INSTALLING THE DRIVELINE

1. Remove the two retaining bolts from the front driveline.
2. Install the driveline onto the gearbox input shaft. Insert the retaining bolts in opposite directions from each other, and tighten the locknuts securely.



CRUSH HAZARD

If the retaining bolts are not present, the driveline could separate from the gearbox, causing serious injury or death. Do not omit the retaining bolts. Tighten the locknuts securely.



3. Attach the safety chain on the driveline guard to the gearbox cover.
4. Separate the two halves of the driveline.

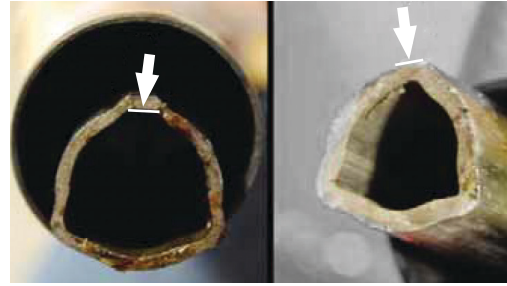

5. Apply a bead of grease around the end of the inner drive shaft.
6. Slide the front driveline half over the rear half. Align the square rib on the mating halves to engage.

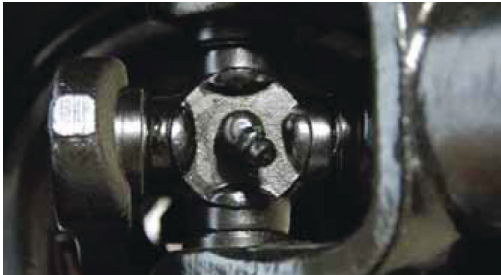

7. Apply grease to the zerks on the U-joint crosses.

5.4 CHECKING THE DRIVELINE LENGTH

Before operating the rotary cutter, it is important to ensure that the driveline will not bottom out or become disengaged. Bottoming out refers to the inner shaft penetrating the outer housing until the assembly cannot shorten any further. This can cause significant damage to the tractor's power take-off (PTO) system, such as pushing the driveline into the tractor and through the support bearings, or downward onto the PTO shaft, potentially breaking it off. A broken driveline can pose a risk of personal injury.

1. Attach the rotary cutter to the tractor following the procedure and observing all warnings in "6.3 Attaching to Tractor" on page 33. However, do not attach the driveline at this point. It is important to keep the driveline out of the way of moving parts.
2. Raise and lower the rotary cutter to determine the maximum and minimum distance between the tractor PTO shaft and the gearbox input shaft. It is important to ensure that the distance is within the appropriate range. If the distance is too large, the driveline will be too short for proper engagement. If the distance is too small, the driveline may bottom out during operation, potentially causing damage to the rotary cutter or tractor.

For safe operation, it is crucial to ensure that there is a minimum of six inches of engagement at the rotary cutter's lowest point of operation. Additionally, the driveline should not bottom out when the cutter is raised to its maximum height. If the driveline is too short and does not provide sufficient engagement, please contact your IronCraft dealer to obtain a longer driveline. On the other hand, if the driveline is too long, follow the provided instructions for shortening the driveline.

5.5 SHORTENING THE DRIVELINE

1. Move the rotary cutter up and down to get the shortest possible distance between the tractor PTO shaft and the gearbox input shaft. Shut down the tractor PTO shaft and the gearbox input shaft. Shut down the tractor leaving the rotary cutter in the position of shortest distance. Securely block the rotary cutter in position.
2. Separate the driveline into two halves and connect them to the tractor PTO and gearbox.
3. Place the driveline halves parallel to one another to determine how much to shorten the driveline.
4. Each section should end approximately 3" short of reaching the universal joint shield on the opposite section. If too long, measure 3" back from the universal joint shield and mark on the opposite driveline shield tube.
5. Repeat Step 4 for the other half of the drive.
6. Raise and lower the rotary cutter to determine the position with the greatest distance between the PTO shaft and the gearbox input shaft. Shut down the tractor leaving the rotary cutter in the position of greatest distance. Securely block the rotary cutter in position.
7. Hold the driveline sections parallel to each other and check for minimum 6" overlap. If the driveline has been marked for cutting, the overlap will be the distance between the two marks. If the driveline has less than the minimum overlap, do not use. Contact your IronCraft dealer.

Note: If the driveline is the correct length, omit the following Steps 8 - 9 and proceed to Step 10.

8. Clamp a driveline section in a well-padded vice to prevent damage to the shield. Cut off the shield tube where marked. Using the cut off section of the shield as a guide, cut the shaft the same amount. Repeat for the other driveline section.
9. File and clean the cut ends of both drive halves. Remove all chips and filings.
10. Apply multi-purpose grease around the inner driveline section. Slide the drive halves over each other several times to distribute the grease. Install the driveline on tractor and rotary cutter. Make certain the driveline shielding is in place and in good condition.

Note: Do not use the rotary cutter if proper driveline engagement cannot be obtained through these methods. Contact your IronCraft dealer.

OPERATION

6.1 USER SAFETY TRAINING

Refer to “2.4 General Safety” on page 8 for user safety training requirements.



WARNING ROLL AWAY HAZARD

Before leaving the tractor seat, make sure the engine is stopped, the transmission is placed in park, the key is removed, and the parking brake is set.



The weight of the tractor, plus the rotary cutter if it rolls onto a person, could cause serious crushing injury or death.



CRUSH HAZARD

The tractor should be equipped with a Roll Over Protective Structure (ROPS) and a seat belt. A crushing hazard could occur if the driver is ejected from the seat while the tractor is in motion. Fasten the seat belt whenever the tractor is moving.

The rotary cutter is top heavy when the wings are raised. To avoid injury or death from rollover, use caution when transporting over uneven surfaces and slow down for turns.



THROWN OBJECT HAZARD

Cutters can throw objects up to 300 feet. To avoid serious injury or death: 1) Keep all thrown object shielding in place. 2) Inspect area for potential thrown objects before cutting. 3) Do not operate rotary cutter with the deck raised. For non-agricultural use, OSHA, ASAE, SAE, and ANSI standards require the use of chain shields or other protective guards at all times. Do not remove the chain shields.



STAY CLEAR

Clear the work area of all unnecessary people and obstructions to prevent personal injury.



CUTTER BLADE CONTACT HAZARD (HAND)

To avoid serious injury or death, keep away from rotating blades. Do not put hands under cutter deck.



CUTTER BLADE CONTACT HAZARD (FOOT)

To avoid serious injury or death, keep away from rotating blades. Do not put feet under rotary cutter deck.



CRUSH HAZARD

Hydraulic or mechanical failure can allow a wing to drop suddenly without warning. Do not allow anyone to walk under or stand near a raised wing when the wing locks are removed.



ENTANGLEMENT HAZARD

Operating the rotary cutter without the driveline shields could result in physical injury or death from entanglement. Make sure all shields are properly installed before operating the rotary cutter. This equipment should never be operated with any safety shielding removed.

SAFETY INSTRUCTIONS

The following safety instructions are provided to help prevent injury or limit equipment damage.



TRAIN UNFAMILIAR USERS

It is the rotary cutter owner's responsibility to make sure any person using the rotary cutter, especially if it is loaned or rented, has been thoroughly trained on its proper and safe use.

Be certain only physically-able persons will use the rotary cutter.



Users who have not read and understood all operating and safety instructions are not qualified to use the rotary cutter.

If the elderly are assisting with the work, their physical limitations need to be recognized and accommodated.

Never allow children to operate equipment.



FIRE HAZARD

Clippings are flammable. To reduce the risk of fire: 1) Do not operate near fires. 2) Keep the rotary cutter deck clear of clippings and debris.

NOTICE

Wing cutting blades may become locked together (overlapped) when the wings are raised for transport. Operating the cutter in this condition will result in severe deck vibration. Inspect the wings for locked blades prior to lowering the wings. Use a pry bar or other tool to free any locked blades.

6.2 TRACTOR REQUIREMENTS

The tractor used to operate the cutter must have the power to lift, pull, and operate the Power Take Off (PTO) at the cutter's rated speed while traveling at a ground speed between 2 and 5 MPH.

The power required to operate the cutter is determined by the tractor PTO horsepower. Operating the cutter with a tractor that does not have adequate power may damage the tractor engine.

MODEL	RECOMMENDED MIN. HP
2512	35 (Gear Drive Transmission)

Operating the cutter with a tractor that does not meet the following requirements may cause trac-



WARNING

Always refer to the tractor owner's manual to ensure compatibility and maximum safety.

tor or cutter damage and be a potential danger to the operator and passersby.

Always review the “controls” section of the tractor operator’s manual to be familiar with the location, settings, and function of the tractor controls. Be familiar with all controls before using this equipment.

6.2.1 EQUIPMENT AND CAPABILITIES:

- ASABE approved Roll-Over Protective Structure (ROPS) or ROPS cab and seat belt.
- Tractor Safety Devices: Slow Moving Vehicle (SMV) emblem, lighting, PTO master shield.
- Front end weight, as needed, to maintain 20% weight on the front axle.
- To reduce the risk of grass fires, do not operate the cutter on a tractor with an underframe exhaust.

6.2.2 TRACTOR SAFETY DEVICES

If transporting or operating the tractor and implement near a public roadway, the tractor must be equipped with proper warning lighting and a Slow Moving Vehicle (SMV) emblem that are clearly visible from the rear of the unit. Lights and a SMV emblem must be attached directly to the implement if the visibility of the tractor warning signals are obscured.



Maintain all manufacturer equipped safety shields and guards. Always replace shields and guards that were removed for access to connect, service, or repair the tractor or implement. Never operate the tractor PTO with the PTO master shield missing or in the raised position.

6.2.3 ROPS AND SEAT BELT



WARNING
ROLLOVER HAZARD

To avoid serious injury or death from falling off tractor, equipment runover, rollover, or crushing:



1. Use a ROPS-equipped tractor.
2. Keep the ROPS locked in the UP position.
3. Only operate the equipment when seated in the tractor seat.
4. Always fasten the seat belt when operating the tractor and rotary cutter.
5. The unit is top heavy when the wings are folded. Use caution when transporting over uneven terrain and slow down for turns.

The tractor must be equipped with a Roll Over Protective Structure (ROPS) (tractor cab or roll bar) and seat belt to protect the operator from falling off the tractor, especially during a roll-over where the driver could be crushed and killed. Only operate the tractor with the ROPS in the raised position and seat belt fastened.

6.2.4 DRAWBAR

The distance between the drawbar hitch pin hole and the end of the tractor PTO shaft must be 14". The distance from the top of the drawbar to the PTO shaft must be 8". PTO damage may occur if these dimensions vary more than 1". The cutter is designed to work with drawbar heights of 16"-19." Using a drawbar configuration outside of this height range may result in a cutter that can not be set up with the right deck pitch.

6.2.5 POWER TAKE-OFF (PTO)

This rotary cutter operates at a PTO speed of 540 RPM. Most tractors operate at either 540 or a combination of 540 and 1000 RPM PTO speeds. The operating speed of the tractor can be determined by the number of splines on the PTO output shaft. Those operating at 540 RPM will have a 6-spline shaft, and those operating at 1000 RPM will have a 20 or 21-spline shaft.

Refer to the tractor Operator's Manual for instructions to change PTO speeds on models that operate at more than one speed.

SAFETY INSTRUCTIONS

If operating an older model tractor where the tractor's transmission and PTO utilize one master clutch, an over-running clutch must be used between the PTO output shaft and the driveline of the rotary cutter. An authorized tractor dealer can provide the over-running clutch and its installation, if needed.

Do not use a PTO adapter to attach a non-matching implement driveline to a tractor PTO. Doing so would be dangerous. Consult an authorized dealer for assistance if the implement driveline does not match the tractor PTO.



WARNING CRUSH HAZARD



The use of a PTO adapter can cause excessive vibration, thrown objects, and blade and implement failure. It can also change the working length of the driveline, exposing unshielded driveline areas. Serious bodily injury or death can result from using a PTO adapter. Therefore, it is advised not to use a PTO adapter to attach a non-matching implement driveline to a tractor PTO.

6.3 ATTACHING TO TRACTOR

Use caution when connecting the rotary cutter to the tractor. The rotary cutter should be securely resting at ground level or setting on blocks. Keep hands and feet from under the deck and clear of pinch points between the tractor drawbar and rotary cutter hitch.



WARNING CRUSH HAZARD

Crush hazard between hitch and implement. Do not allow anyone to stand between the hitch and implement during hook-up operations.

1. Use the jack to adjust the hitch to the height of the tractor drawbar.
2. Board the tractor and start the engine. Back the tractor up to the cutter hitch until the holes in the drawbar and clevis are aligned.
3. Turn off the tractor engine and dismount. Make sure the parking brake is engaged.
4. Insert a high strength drawbar pin, 1.0" Diameter minimum, through the clevis and drawbar holes and install retaining pin. Do not use a homemade or shop made pin.
5. See diagram for correct hitch clevis orientation



CLEVIS HINGE
IS UP

DUCK BILL
IS DOWN



WARNING CRUSH HAZARD

Unexpected separation of the cutter from the tractor can cause death or serious injury. Use only an OEM high-strength drawbar pin. Do not use a homemade or shop-made pin.

6. Connect the hitch safety chain to the tractor drawbar cage. The safety chain should be long enough to allow for tight turns, but not long enough to drag on the ground.
7. Retract the jack, remove the locking pin, move the jack to its storage location on the cutter deck, and secure it with the locking pin.
8. Pull back on collar (1) on the tractor end of the driveline.
9. Push the driveline onto the tractor PTO shaft until the collar snaps forward.
10. Pull back on driveline guard (2) to check that the driveline is latched. Do not pull back on the collar, as this will release the driveline.

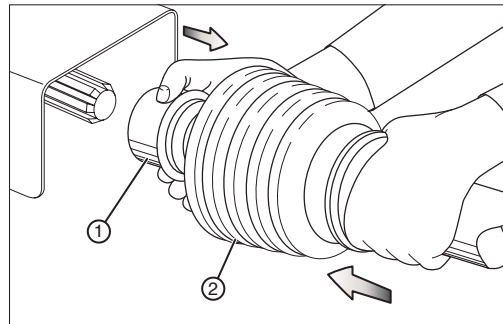

11. Attach the safety chain on the driveline guard to the tractor.
12. Inspect all the hydraulic hoses to ensure they are in good condition. Route the main lift hydraulic hose through the hose rack, make sure the fitting is clean, and attach to the tractor's hydraulic port. Make sure the hose is adequately supported so it cannot come in contact with other parts or the ground.



13. Make sure the driveline has adequate clearance through the full range of cutter height adjustment. Adjust tractor drawbar height and/or length if there is interference. See 6.2.4 Drawbar on page 32 for correct drawbar dimensions.



WARNING
ENTANGLEMENT HAZARD

Operating the tractor PTO without the driveline shields could result in physical injury or death from entanglement. Make sure all driveline shields are properly installed before operating the PTO. Make sure all motion has stopped before attaching or detaching the driveline.



6.4 SETTING THE ROTARY CUTTER

Properly setting the rotary cutter is essential for efficient and safe operation. A properly set rotary cutter will make a more uniform cut, distribute clippings more evenly, require minimal tractor work, and follow the contour of uneven terrain. The two adjustments to make before cutting are:

- Leveling front-to-back (*for initial set up we recommend the front of the cutter be set a little lower than the back*)
- Cutting height

NOTICE

Avoid very low cutting heights. Striking the ground with the blades causes damaging shock loads and will cause damage to the rotary cutter and drive.



WARNING
PROJECTILE HAZARD

Blades contacting the ground may cause objects to be thrown out from under the cutter deck. Do not operate the rotary cutter at a height which causes the blades to contact the ground.



6.4.1 LEVELING FRONT-TO-BACK

1. Locate the tractor and cutter on a flat, level surface and use the hydraulics to adjust the cutter height until the front skid shoes are two to three inches off the ground.
2. Shorten or lengthen the leveling rods, as needed, to obtain the desired cutting results. Lengthening the leveling rods raises the back of the cutter.
 - a. Operating the rotary cutter with the deck approximately 3/4" higher in the rear than the front will allow the rotary cutter to cut the grass only once and requires less work from the tractor.
 - b. Operating the rotary cutter with the deck approximately 3/4" higher in the front than the rear will increase mulching of the grass or crop material.
 - c. Operating the rotary cutter at any position other than level with the ground will result in a slightly uneven cut.
3. Make sure the leveling rods have equal amounts of tension, and tighten the adjuster jam nuts.

6.4.2 SETTING THE CUTTING HEIGHT

The rotary cutter should be operated at the highest position that will give the desired cutting results. This will help prevent the blades from striking the ground, increasing blade life, and reducing stress on the rotary cutter and tractor.

1. Park the tractor and rotary cutter on level ground.
2. Using the tractor hydraulic cylinder control lever, position the front of the center deck with the center skid shoes 1" lower than the desired cut height. For example, for a 3" cut, position the skid shoes 2" from the ground. Set the control lever stop at this position to maintain this height when raising and lowering the cutter.
3. Check the wing decks and re-level them if needed. Refer to "5.2.2 Leveling the Wing Decks" on page 25.

6.4.3 WING STOP ADJUSTMENT

When raised, the wings should contact the stops when the wing lock hole is aligned with the pin. If adjustment is necessary:

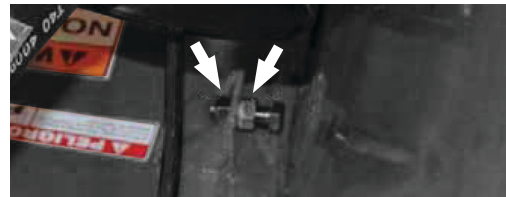







1. Raise the wings with the tractor hydraulics and install the wing locks.
2. Loosen the lock nuts on the wing stop bolt on one wing, and make sure the wing stop bolt does not touch the wing.



3. Adjust the lock nuts so that the wing stop bolt contacts the raised wing.
4. Tighten the lock nuts.
5. Repeat Steps 2-4 for the other wing.

6.5 INITIAL SETUP CHECKLIST

Efficient and safe operation of the rotary cutter requires that every user read and understand the operational instructions and all related safety instructions outlined in this manual.

This checklist is provided for the user/owner. It is important for both personal safety and to maintain the mechanical condition of the rotary cutter that this checklist is followed.

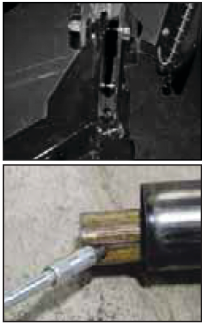
Initial Setup Checklist (prior to using for the first time)		
✓	Location	Task
✓		Verify all safety signs are in place and legible. Refer to "3.3 Safety Sign Locations" on page 19.
✓		Make sure the rotary cutter is properly attached to the drawbar. Refer to "6.3 Attaching to Tractor" on page 33.
✓		Make sure the driveline is attached to the tractor PTO, and safety chains are installed. Refer to "6.3 Attaching to Tractor" on page 33.
✓		Make sure all hardware is properly installed and tightened. Refer to "9.13 Bolt Torque Requirements" on page 56.
✓		Make sure the blades are sharp. Refer to "9.6 Blade Servicing" on page 56.
✓		Make sure the blade carrier nuts are tight and the cotter pins installed. Refer to "9.7 Blade Carrier Removal" on page 51.

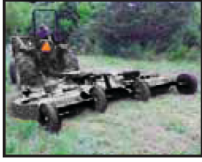
Initial Setup Checklist (prior to using for the first time)		
✓	Location	Task
✓		Lubricate all grease zerks and driveline slip joints. Refer to "9.3 Greasing" on page 50.
✓		Make sure all safety shields and guards are properly installed. Refer to "5.2 Assembly Procedure" on page 22.
✓		Check the tailwheels for damage. Make sure the tailwheel support bolts are tight.
✓		Check the cutting height. Adjust if needed. Refer to "6.4.2 Setting the Cutting Height" on page 35.

6.7 PRE-OPERATION CHECKLIST

Before each use of the rotary cutter, the following areas should be checked.

CHECKLIST BEFORE EACH USE	
✓	TASK
	Make sure the rotary cutter is positively attached to the tractor drawbar. Refer to “6.3 Attaching to Tractor” on page 33.
	Make sure the hydraulic hoses are undamaged, are secured on the hose rack, and cannot contact the tractor when turning or drag on the ground.
	Use only an appropriately-sized tractor to pull the rotary cutter. Refer to “6.2 Tractor Requirements” on page 30.
	Make sure the driveline is securely attached to the tractor PTO. Refer to “6.3 Attaching to Tractor” on page 33.
	Make sure all safety shields and guards are properly installed.
	Check the blade bolts and blade carrier nuts. Refer to “9.6 Blade Servicing” on page 51.
	Inspect wing blade carriers and blades for locked blades prior to lowering the wings. Use a pry bar or other tool to separate locked blades.
	Check the condition of the blades. Refer to “9.6 Blade Servicing” on page 51.
	Check the cutting height. Adjust if needed. Refer to “6.4.2 Setting the Cutting Height” on page 35.
	Inspect the overall rotary cutter for potential problems or damage. Do not use the rotary cutter if it needs repairs of any type.
	Make sure the driveline CV joints, U-joints, and slip joints are greased. Refer to “9.5 Driveline Lubrication” on page 51.

6.8 GENERAL OPERATING PROCEDURE

Although the rotary cutter is easy to use, each operator should review this section to familiarize themselves with the detailed safety and operating procedures.

1. Operate the rotary cutter only in conditions where you have clear visibility in daylight or with adequate artificial lighting. Never operate the rotary cutter in darkness or foggy conditions where you cannot clearly see at least 300 feet in front and to the sides of the tractor and rotary cutter. Make sure that you can clearly see and identify passersby, steep slopes, ditches, drop-offs, overhead obstructions, debris, and foreign objects. If you are unable to clearly see these type of items, discontinue operating the cutter.
2. Clear the area of bystanders, especially small children.
3. Clear the area to be cut of stones, branches, debris, and any hard objects that may be thrown. Also remove objects such as wire, cable, rope, or chains, that can become entangled in the blades. Never operate the rotary cutter in an area that you have not inspected and removed debris or foreign material. Mark the location of objects that cannot be removed.



WARNING CRUSH HAZARD



Objects such as wire, cable, rope, or chains can become entangled in the rotating parts of the cutter. These items could then swing outside the deck at greater velocities than the blades. This is extremely hazardous and could result in serious injury or even death. Inspect the cutting area for such objects before mowing, and remove them. Never allow the blades to contact such items.

4. Do not operate the rotary cutter or drive the tractor into material that is burning or areas that recently burnt and may contain hot spots. Burning material, sparks, and coals could be thrown from the rotary cutter to areas of vegetation that might ignite. Tire damage can occur when driving over hot material. Oil and grease on the tractor and rotary cutter could ignite, resulting in equipment destruction. Carry a fire extinguisher on the tractor at all times to extinguish possible fires encountered. Do not operate the rotary cutter on a tractor with an underframe exhaust.
5. Whenever using a rotary cutter in dry grass, be aware that a thrown metal object can create a spark against the blade or metal deck housing. Take extra precautions in this type of dry situation to prevent fires.
6. Engage the PTO at low engine RPM, then raise PTO speed to 540 RPM.
7. Begin cutting at a slow speed, then increase to a speed that gives a clean cut without lugging the engine. Do not operate above 5 MPH.
8. Never allow blades to contact solid objects like rocks, posts, wire, curbs, guardrails, or the ground while mowing.

9. When you get to the end of a pass, slightly raise the rotary cutter (2-4") before turning. Never raise the rotary cutter entirely while the blades are turning. If the rotary cutter must be raised higher than 12" from ground level, disengage the tractor PTO and wait for all blade rotation to come to a complete stop before raising the rotary cutter.



WARNING
THROWN OBJECT HAZARD



Operating the PTO with a wing in the folded position could cause the driveline to break and throw objects at the operator or a bystander, causing serious injury or death. Do not engage the PTO with either wing folded up.

10. When turning, the angle between the tractor and rotary cutter must not exceed 80°. This extreme angle is intended for intermittent use only. Plan your cutting to minimize extreme turning angles. Sharp turns can cause premature failure of the joints and put pressure on the tractor PTO shaft, and could cause extensive mechanical damage to the rotary cutter and tractor.
11. When making tight turns, ensure that the tractor tires and lower 3-point arms do not make contact with the cutter. Keep the 3-point hitch raised whenever the tractor is hitched to a pull-type cutter.
12. Do not operate a pull-type cutter at an angle exceeding 25 degrees up or down or at any angle that will force the driveline to bind and/or hit the tractor drawbar.
13. Large, dense, or wet vegetation may need to be cut in two or more passes to achieve a uniform cut. In such conditions, raise the cutting height to 12" or more on the first pass. Then lower the rotary cutter to the desired height and mow the vegetation a second time. If possible, select a cutting direction that is at a 90-degree angle to the first pass to reduce streaking for a more uniform cut.
14. Stay alert and watch for trees, low hanging limbs, power lines, and other overhead obstacles while operating. Use care to avoid hitting these items.
15. Avoid cutting in reverse. Instead, disengage the PTO, wait for the blades to stop, and raise the deck. Back up into the area to be cut. Lower the deck, engage the PTO, and cut forward. Do not back the rotary cutter into solid objects. The joint where the hitch attaches to the deck will pivot upward, allowing the front edge of the deck to contact the driveline. Check to make sure there are no persons behind the rotary cutter, and use extreme care when maneuvering in reverse.
16. Always cross steep ditches and banks at a diagonal. Never cross straight across and never back into a steep ditch or bank. Cutting over ditches and backing up hills can "Bottom Out" the driveline. Bottoming out is when the driveline shaft has shortened to the point it is pressing against the gearbox and tractor PTO shafts. Once a driveline has bottomed out, it cannot be shortened anymore without causing serious damage to the tractor PTO components, cutter gearbox, and driveline.

6.9 CHAIN SHIELDING

IronCraft installs full chain shielding as standard equipment on all flex-wing rotary cutters.



WARNING PROJECTILE HAZARD



The chain shielding is designed to reduce the risk of thrown objects. The rotary cutter deck and protective devices cannot prevent all objects from escaping the blade enclosure in every mowing condition. It is possible for objects to ricochet and escape, traveling as much as 300 feet. Death or serious injury could result from being struck by a thrown object. Do not operate the cutter if the chain shielding is missing or damaged.

1. Full chain shielding must be installed when operating in populated areas or other areas where thrown objects could injure people or damage property.
2. If the chain shielding is missing or damaged, operation must be stopped until it can be repaired or replaced.
3. Inspect chain shielding each day of operation and replace any broken or missing chains, as required.

6.10 RIGHT OF WAY (ROADWAY) MOWING

Use double chain shields for highway, right-of-way, parks, greenbelt mowing, or all other mowing where human dwellings, vehicles, or livestock could be within 300 feet of the cutter.

No shielding is 100% effective in preventing thrown objects. To reduce the possibility of injury:

1. Maintain rotary cutter shielding in good operational condition.
2. Inspect the condition of the thrown object guards, cutter side skirts, and skid shoes daily: Replace or repair worn or damaged guards.
3. Inspect the condition of the blades and blade bolts daily. Replace any cracked, worn, bent, or damaged blades. Always replace blade bolts and lock washers when replacing blades. Make sure the blade bolts are properly tightened.
4. Raise cutting height to a minimum of 6".
5. Never allow blades to contact solid objects like rocks, posts, wire, curbs, guardrails, or the ground while mowing.

Rotary cutters can throw objects 300 feet or more under certain conditions. To avoid serious injury or death from thrown objects:

1. Inspect the area thoroughly for potential thrown objects and remove them before cutting.
2. Remove debris, rocks, wire, cable, metal objects, and other foreign material from the area.
3. Wire, cable, rope, chains, and metal objects can be thrown or swung outside the deck with great velocity.
4. Mark the location of objects that cannot be removed so they can be avoided when mowing.

Stop mowing if passersby are within 300 feet unless:

1. All thrown object shielding, including front and rear deflectors, chain shields, steel guards, bands, side skirts, and skid shoes are in place and in good condition when mowing.
2. Mower sections or wings are adjusted to be close and parallel to the ground without exposing blades.
3. The mowing area has been inspected and foreign materials and debris have been removed.
4. Passersby are inside an enclosed vehicle.

6.11 DETACHING FROM TRACTOR

1. Disengage the PTO and wait for blade rotation to come to a complete stop. Raise the rotary cutter with the tractor hydraulics and install the transport lock on the lift cylinder.
2. Raise the wings with the tractor hydraulics and install the wing locks.



WARNING
CRUSH HAZARD



Hydraulic or mechanical failure can allow a wing to drop suddenly without warning. Do not allow anyone to walk under or stand near a raised wing when the wing locks are removed.

3. Park the tractor, place the transmission in park or neutral, and apply the parking brake. Lower the rotary cutter onto blocks placed under the front skid shoes. Shut down the engine, remove the key, and move the cylinder operating lever in both directions to relieve hydraulic pressure. Wait for all motion to come to a complete stop before exiting the tractor.
4. Make sure the rotary cutter is resting securely on the ground or blocks, and chock the cutter wheels before attempting to disconnect it from the tractor. Use extreme care to keep feet and hands from under the rotary cutter and clear of any pinch points caused by the tractor drawbar and rotary cutter hitch.
5. Remove the jack from the cutter deck and secure it to the hitch by fully inserting the locking pin through the jack and the hitch bracket. Use the jack to raise the cutter hitch to the height needed to disconnect the clevis from the drawbar.
6. Disconnect the hydraulic hose from the tractor. Store the hose on the cutter deck.



CAUTION
EXPLOSIVE SEPARATION HAZARD



Be sure all hydraulic pressure is relieved before disconnecting hydraulic lines or fittings between the rotary cutter and the tractor hydraulic system.

Escaping hydraulic fluid under pressure, even a pinhole size leak, can penetrate body tissue, causing serious injury and possible death. If fluid is injected into your skin, it must be treated immediately by a doctor familiar with this type of injury.

7. Disconnect the driveline safety chain and hitch safety chain.
8. Pull back on the collar on the tractor end of the driveline.
9. Slide the driveline off the tractor PTO shaft and secure it up off the ground.
10. Remove the hitch pin and drive the tractor away from the rotary cutter.

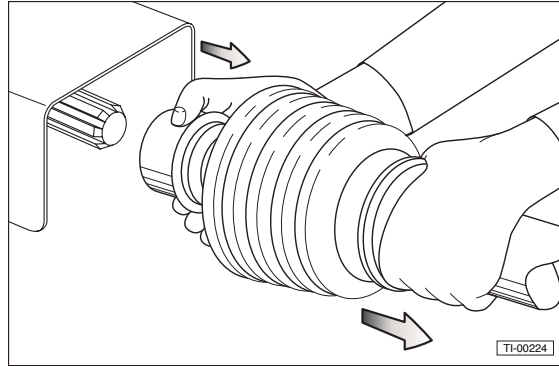

TRANSPORTING

7.1 TRANSPORTING SAFETY (ROAD)



WARNING

Failure to understand and follow these safety instructions could result in serious injury and possibly even death.



TRACTOR OWNER/OPERATOR MANUAL

Always refer to the tractor owner's manual to determine its compatibility and maximum safety.



OPERATING THE TRACTOR

Before attaching the rotary cutter to the tractor, be familiar with its controls and how to stop it quickly in the event of an emergency. Read and understand this manual and the one provided with your tractor before transporting the rotary cutter.



FALL AND CRUSH HAZARD

Do not allow riders on the rotary cutter or tractor.



MAXIMUM TRANSPORTING SPEED

Do not exceed 15 MPH when transporting the rotary cutter. Slow down for corners and rough terrain.



VISIBILITY

Clean reflectors, SMV or SIS sign, and tractor tail lights before towing. Make sure all the lights and reflectors required by highway and transport authorities are in place and can be seen clearly by all overtaking and oncoming traffic.



REGULATIONS

Make sure all local, state, and federal regulations regarding the transport of equipment on public roads and highways are met. Check with the local authorities regarding transporting the rotary cutter on public roads. Obey all applicable laws and regulations.



ROLLOVER PROTECTION

The tractor should be equipped with a Roll Over Protective Structure (ROPS) and a seat belt. The cutter is top heavy when the wings are folded. Use caution when transporting over uneven surfaces and slow down for turns.

SAFETY INSTRUCTIONS

The following safety instructions are provided to help prevent injury or limit equipment damage.



DRIVE SAFELY

Be a safe and courteous driver. Anticipate what other drivers will do and drive accordingly.



ALLOW EXTRA DISTANCE

Apply brakes early. Leave extra distance between your vehicle and the one(s) ahead to provide adequate stopping space. Extra distance will be required to stop the vehicle.



CLEAR VISION

Remove all objects from the area that would prevent clear vision of the complete work area or would present an obstacle when moving the rotary cutter.



HITCH ATTACHMENT

Be sure the rotary cutter is securely attached to the tractor and in good operating condition before using.



WORKING TAILLIGHTS

Make sure lights on the tractor are working properly.



ADDITIONAL LIGHTING

For rotary cutters without lights, install additional lights on the rear of the tractor to safeguard against rear-end collisions. Daybreak and dusk are particularly dangerous, and rear pilot vehicles are recommended. Rotary cutters without lights should be transported on public roads only during daylight hours.



HAZARD FLASHERS

Use hazard flashers on the tractor when transporting unless prohibited by law.



RIGHT-OF-WAY

When traveling below the posted speed limit, keep to the right and yield the right-of-way to allow faster traffic to pass.

NOTICE

Laminated sectional tires are designed for conditions where puncture-proof performance is required and the rotary cutter will not be transported for long distances on roadways. Transport speed for laminated tires should not exceed 15 MPH. Excessive speed can cause damage to the machine and tire sections.

7.2 TRANSPORTING PROCEDURE

1. Make sure the towing safety chain on the rotary cutter hitch is attached to the tractor drawbar cage. The safety chain should be long enough for tight turns. Don't allow the chain to drag on the pavement because it will wear the chain links, causing an unsafe condition.
2. Prior to towing, make sure the brakes, brake lights, running lights, turn signals, and hazard lights on the tractor are operating correctly.
3. Raise the rotary cutter with the tractor hydraulics. Place the transport lock over the wheel lift cylinder rod. Insert and lock the retaining pin.





WARNING THROWN OBJECT HAZARD



Operating the PTO with a wing in the folded position could cause the driveline to break and throw objects at the operator or a bystander, causing serious injury or death. Do not engage the PTO with either wing folded up.

4. Make sure the jack stand is secured in its storage location on the left wing deck.
5. Fold the wings onto the wing rests.

NOTE: The center deck will raise fully up before the wing cylinders start to fold the wings.

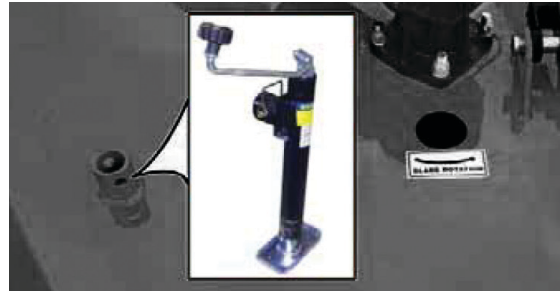

PINCH POINT HAZARD

Do not place hands or fingers between moving and/or stationary parts. The weight of the unit could easily cause serious bodily injury.



CRUSH HAZARD

After raising the wings, make sure to install both wing locks.

6. Install the wing lock bars and their retaining pins.
7. Tow the cutter to the work site following all applicable regulations and all the safety instructions in this manual.

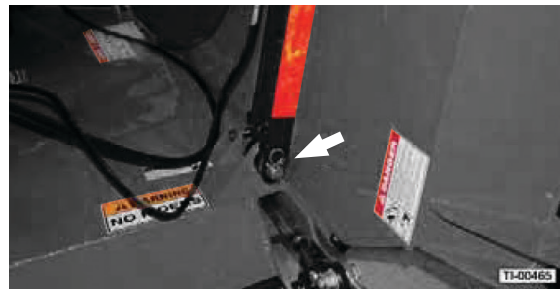

CRUSH HAZARD

The rotary cutter is top heavy when the wings are raised. To avoid injury or death from rollover, use caution when transporting over uneven surfaces and slow down for turns.

STORAGE

8.1 STORAGE SAFETY

At the end of the season, the rotary cutter should be thoroughly inspected and prepared for storage. Repair or replace any worn or damaged components to prevent any unnecessary downtime at the beginning of the next season.



WARNING ROLLOVER HAZARD



The rotary cutter is top heavy when the wings are raised. To avoid injury or death from rollover, store the cutter on a firm, level surface.



CAUTION PERSONAL INJURY HAZARD



Store the rotary cutter in an area away from human activity. To prevent the possibility of serious injury, do not permit children to play on or around the stored rotary cutter.

NOTICE

To prevent damage to the rotary cutter, store it in a dry, level area.

8.2 PLACING IN STORAGE

1. Remove all entangled vegetation.
2. Thoroughly wash the rotary cutter with a pressure washer or water hose to remove all clippings, dirt, mud, or debris.
3. Raise the rotary cutter with the tractor hydraulics and install the transport lock on the lift cylinder.
4. Raise the wings with the tractor hydraulics and install the wing lock bars and their retaining pins.
5. Select an area that is dry, level, and free of debris (inside a building is ideal). Move the rotary cutter to its storage area. Disconnect the rotary cutter from the tractor following the procedure in “6.11 Detaching From Tractor” on page 41.
6. Lubricate all grease points. Make sure all grease cavities have been filled with grease to remove any remaining water from washing.
7. Touch up all paint nicks and scratches to prevent rusting.

8.3 REMOVING FROM STORAGE

1. Grease all lubrication points. Refer to “9.3 Greasing” on page 50.
2. Attach the rotary cutter to the tractor following the procedure in “6.3 Attaching to Tractor” on page 33.
3. Check for locked blades before lowering the wings. Use a pry bar or similar tool to free any locked blades.

NOTICE

Wing cutting blades may become locked together (overlapped) when the wings are raised for transport or storage. Operating the cutter in this condition will result in severe deck vibration. Inspect the wings for locked blades prior to lowering the wings. Use a pry bar or other tool to free any locked blades.

4. Before placing the rotary cutter back into service, replace any worn, damaged or defective parts and perform the Pre-Operation Checklist.
5. Check the operation of the slip clutches. Refer to “9.9 Slip Clutch Operational Check” on page 53.

SERVICE AND MAINTENANCE

9.1 MAINTENANCE SAFETY

At the end of the season, the rotary cutter should be thoroughly inspected and prepared for storage. Repair or replace any worn or damaged components to prevent any unnecessary downtime at the beginning of the next season.



WARNING

Failure to comply with the following safety instructions could result in serious injury and possibly even death if they are not understood and followed.

PERSONAL PROTECTION EQUIPMENT

Wear close fitting and belted clothing to avoid getting caught in moving parts.



Wear personal protective equipment (PPE), such as a hard hat, safety glasses, safety shoes, gloves, etc., appropriate for the work site and working conditions.



DISCONNECT DRIVELINE

To prevent injury due to possible unexpected movement, disconnect the driveline from the tractor PTO before performing any maintenance procedure.



DAMAGED PARTS HAZARD

Do not use the rotary cutter if any parts are damaged. If the rotary cutter is believed to have a defect that could cause it to work improperly, immediately stop using it and remedy the problem before continuing.



NO UNAUTHORIZED MODIFICATIONS

Do not modify the rotary cutter or safety devices. Do not weld on the unit. Unauthorized modifications may impair the cutter's function or create safety hazards and will void the warranty.

If the rotary cutter has been altered in any way from the original design, the manufacturer does not accept any liability for injury or warranty.



CRUSH HAZARD

Always set the rotary cutter on safety stands or on the ground and chock the wheels when performing maintenance.



GOOD WORKING CONDITION

Keep all parts in good condition and properly installed. Fix damage immediately. Replace worn or broken parts.



REPLACEMENT PARTS

If replacement parts are necessary, genuine factory replacement parts must be used to restore the unit to its original specifications.

Unapproved parts could create a safety hazard. The manufacturer will not accept responsibility for damages as a result of the use of unapproved parts.



SAFETY SHIELDS AND DEVICES

When completing a maintenance or service function, make sure all safety shields and devices are installed before placing the rotary cutter in service.



CRUSH HAZARD

The wings may drop unexpectedly if the wing locks are not installed. To avoid serious injury or death from crushing, always make sure the lock bars and their retaining pins are properly installed whenever the wings are raised.

The rotary cutter is top heavy when the wings are raised. To avoid injury or death from rollover, make sure the cutter is on a firm, level surface.



TRAPPED AIR HAZARD

When installing, replacing, or repairing hydraulic system cylinders or parts, make sure that the entire system is charged and free of air before resuming operations. Failure to bleed the system of all air can result in improper machine operation, causing severe injury.



ZERO PRESSURE

Relieve pressure from the hydraulic system before servicing or disconnecting from the tractor.



EXPLOSIVE SEPARATION HAZARD

Replace any worn, cut, abraded, flattened, or crimped hoses.



HIGH-PRESSURE FLUID HAZARD

Keep all hydraulic lines, fittings, and couplers tightly secured and free of leaks.

Do not make any temporary repairs to the hydraulic lines, fittings, or hoses using tape, clamps, or cement. The hydraulic system operates under extremely high pressure, and temporary repairs may fail suddenly and create a hazardous/dangerous situation.

DO NOT use your bare hand to check for potential leaks. Always use a board or cardboard when checking for a leak.

Escaping hydraulic fluid under pressure, even a pinhole size leak, can penetrate body tissue, causing serious injury and possible death. If fluid is injected into your skin, it must be treated immediately by a doctor familiar with this type of injury.

SAFETY INSTRUCTIONS

The following safety instructions are provided to help prevent injury or limit equipment damage.



SAFETY EQUIPMENT

A fire extinguisher and first aid kit should be readily accessible while performing maintenance on this equipment.



CLEAN WORK AREA

Do not leave tools lying around the work area. Follow good shop practices. Keep the service area clean and dry. Be sure electrical outlets and tools are properly grounded. Use adequate light.



USE THE RIGHT TOOLS

Use the correct tools, jacks, hoists, or other tools that have the capacity for the job.



PROPER SUPPORT

Use certified safety stands rated to support the load when working beneath the rotary cutter or performing repairs, service, or maintenance.

The rotary cutter weighs 2630 lbs. Before working underneath, place it on a minimum of four jack stands, with a load rating of at least 2000 lbs. each.

Do not position the jack stands under wheels, axles, or wheel supports, as they may rotate and cause the rotary cutter to fall.

Make sure the jack stands are stable and the rotary cutter deck is approximately level. Test the stability of the rotary cutter before working underneath.

If the rotary cutter is attached to the tractor, set the brakes, remove the key, chock the tractor wheels, and block the rotary cutter before working underneath.

9.2 WELDING REPAIRS



Before performing any type of welding repair to the rotary cutter, contact IronCraft for approval. Repair welding must be done with care and with procedures that may be beyond the capabilities of the ordinary welder.



WARNING PROJECTILE HAZARD



Do not attempt to weld on the blades. They are hardened and will crack or otherwise be damaged, causing failure and possible serious injury or death from thrown blades.



PERSONAL INJURY HAZARD

Repairs or modifications to the rotary cutter can result in serious injury or death should these repairs fail.

NOTICE

Anyone performing a welding repair should be certified in accordance with the American Welding Society (AWS) standards.

9.3 GREASING

See the diagram for the location of all grease zerks.

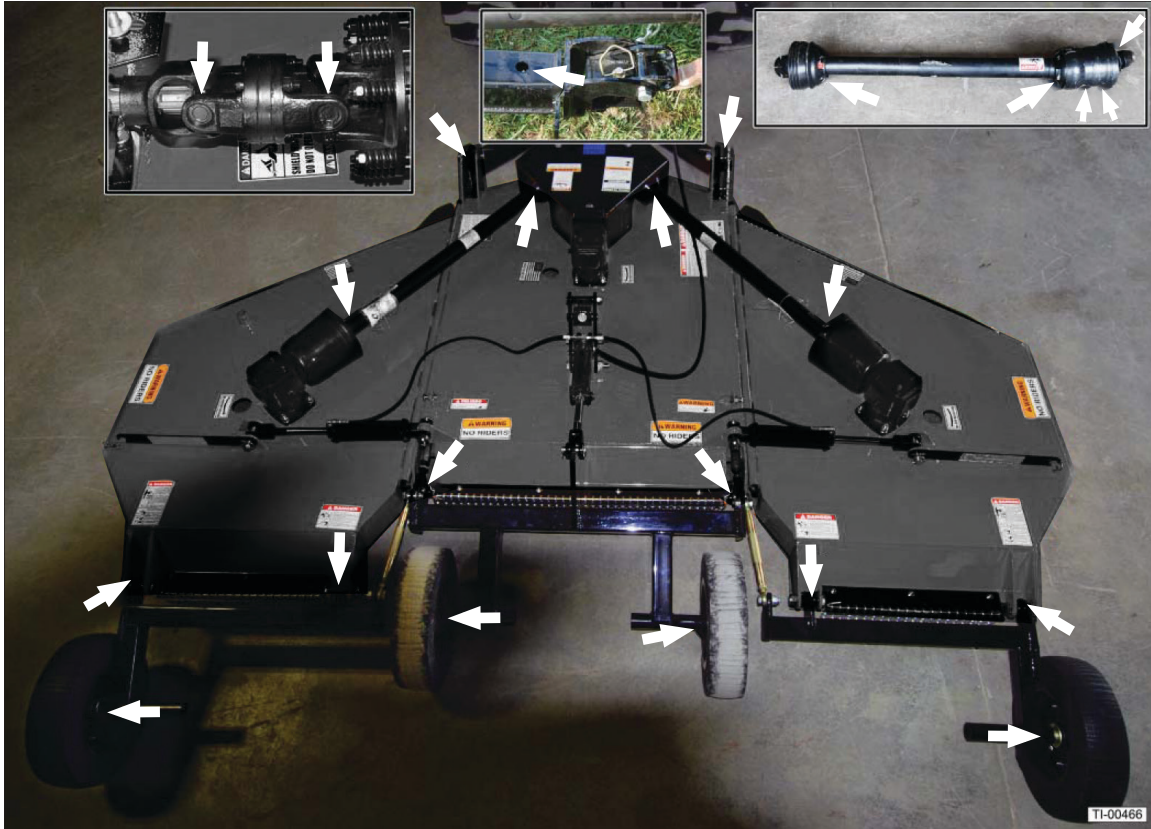

Grease all zerks according to the intervals specified in “9.14 Service Record” on page 57. Use an SAE multipurpose high-temperature grease with extreme pressure (EP) performance. An SAE multipurpose lithium base grease is also acceptable. Here are some guidelines for greasing:

- Always use a handheld grease gun for all greasing.
- Wipe grease zerks with a clean cloth before greasing to avoid injecting dirt and grit.
- Apply grease until new grease can be seen coming out of the joint.
- Do not let excess grease collect on or around parts, particularly when operating in sandy areas.
- Replace broken grease zerks immediately.
- If any grease zerk will not take grease, remove and clean it thoroughly. Also, clean the lubricant passageway. Replace the zerk if necessary.

LOCATION	QTY.
Receiver Swivel	1
Hitch Pivot Bushings	2
Front Driveline CV Joint	2
Front Driveline U-Joints	3
Wing Driveline U-Joints	4
Splitter Cross Shaft U-Joints	2
Tailwheel Tube Pivot Bushings	6
Tailwheel Hubs	4

9.4 GEARBOX LUBRICATION

The gearboxes are filled at the factory and should require no maintenance. If there is evidence of leakage, check the grease level and add grease until it reaches the proper level. Recommended lubricant is EP-0 Grease. Splitter gearbox capacity is 58 ounces. Outboard gearbox capacity is 35 ounces.

Note: Make sure the rotary cutter is level when checking the gearbox grease.

Note: Overfilling the gearbox can cause pressure buildup and seal leakage.

9.5 DRIVELINE LUBRICATION

Lubricate all driveline slip joints, U-joint crosses, and the center driveline CV joint every eight operating hours.

1. Lower the rotary cutter to the ground, disconnect the center driveline from the tractor PTO shaft, and slide the halves apart but do not disconnect from each other.
2. Apply a bead of grease completely around the male half where it meets the female half. Slide the drive halves over each other several times to distribute the grease.
3. Remove the splitter gearbox shield, and disconnect the wing drivelines from the splitter gearbox.
4. Repeat Step 2 for each wing driveline.
5. Rotate the front driveline safety shield until the holes in the shield match up with the grease zerks in the CV joint and U-joint.
6. Apply grease to all accessible grease zerks.
7. Rotate the driveline shield 180° until the holes on the opposite side align with the remaining grease zerks, and apply grease.
8. Repeat for the U-joint at the rear of the center driveline, and at both ends of the wing drivelines.
9. Grease the zerks on the splitter cross shaft.
10. Re-connect the drivelines and re-install the splitter gearbox shield.

9.6 BLADE SERVICING

Inspect the blades before each use to determine that they are properly installed and in good condition. If any blade is bent, excessively nicked, worn, or has any other damage, replace both blades on the spindle. Small nicks can be ground out when sharpening. Always replace blade bolts and lock washers and nuts when replacing blades.

Manually rock the blade carriers to check for any looseness. Recheck torque every fifty hours. Retighten any loose parts.

9.6.1 BLADE REMOVAL



To remove the blades for sharpening or replacement, remove the nut and lock washer from the blade bolt through the inspection hole in the deck of the mower near the gearbox.

9.6.2 BLADE INSTALLATION

When installing blades, be sure to check the blade bolt pivot diameter for wear. Replace the bolt if worn. Tighten the nut to 600 ft. lbs. Always use a new lockwasher and nut when replacing the blade bolt. Make sure the blades are installed with the cutting edge in the direction of rotation. The left and center spindles rotate counterclockwise as viewed from above the deck. The right spindle rotates clockwise as viewed from above the deck.

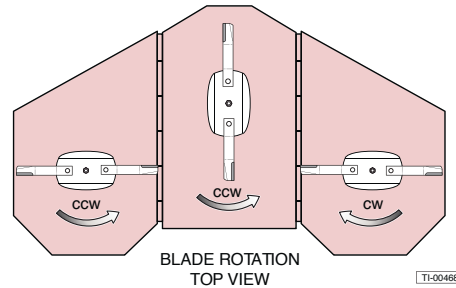

9.6.3 BLADE SHARPENING



CAUTION SHARP OBJECT HAZARD



Store the rotary cutter in an area away from human activity. To prevent the possibility of serious injury, do not permit children to play on or around the stored rotary cutter.

When sharpening blades, always sharpen both blades at the same time and grind the same amount on each blade to maintain balance.

NOTICE

Unbalanced blades will cause excessive vibration, which can damage gearbox bearings. Vibration may also cause structural cracks to the rotary cutter.

Follow the original sharpening pattern. Do not sharpen blades to a razor edge; leave a 1/16" blunt edge. Do not sharpen the back side of the blade. Do not heat and pound out the edge.

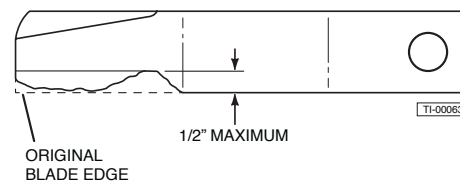
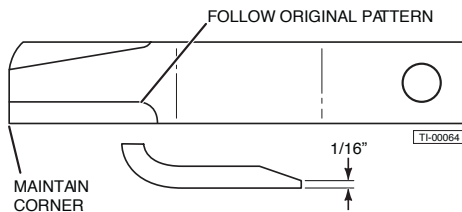

9.7 BLADE CARRIER REMOVAL

1. Remove the cotter pin and loosen the castle nut on the gearbox shaft. Do not remove the nut until the blade carrier is loosened.
2. Use a suitable two jaw gear puller to pull the carrier off the tapered gearbox shaft.
3. Remove the castle nut and the blade carrier.

9.8 BLADE CARRIER INSTALLATION

1. Clean the splines on both the blade carrier and the output shaft.
2. Position the carrier on the gearbox output shaft (per image in 9.6.2) and install the castle nut. Tighten the nut to 450 ft. lbs.
3. Strike the carrier near the hub several times with a heavy hammer to seat the hub. Use care not to strike the nut or the end of the shaft.
4. Retighten the nut to 700 ft. lbs.
5. Install the cotter pin and spread the tangs.

9.9 SLIP CLUTCH OPERATIONAL CHECK

The rotary cutter is equipped with three slip clutches, with one located in front of each spindle gearbox. The slip clutches serve as overall protection for the tractor, driveline, and gearboxes. New clutch assemblies are “run-in” and checked for torque prior to shipment. If the slip clutches have been exposed to weather for an extended period of time, the clutch facing and plates should be inspected for rust and/or corrosion, which may inhibit function. After the rotary cutter has been stored for thirty days or more, perform the following check:

1. Mark a pencil line across the edges of the clutch plates and friction discs.
2. Loosen the eight nuts holding the clutch springs exactly two full turns. Hold the bolt so that it does not turn.
3. Start the tractor and engage the tractor PTO drive for 2-3 seconds. Disengage the PTO, then reengage for an additional 2-3 seconds. The clutch should slip without turning the blades. Disengage the PTO, shut down the engine, remove the key, and wait for all motion to come to a complete stop before exiting the tractor.
4. Verify that the pencil lines have changed position. If the marks are still aligned, the clutch did not slip. If the clutch did not slip, it will need to be disassembled to separate the clutch plates from the friction discs. Refer to “9.11 Slip Clutch Disassembly/Assembly” on page 55.

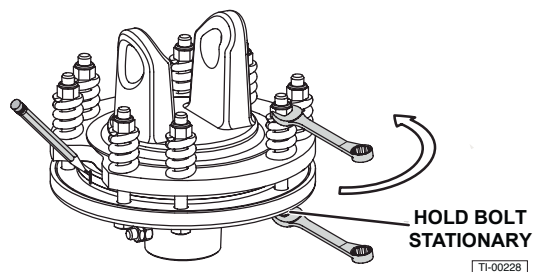

- Retighten the eight nuts to their original position.

NOTICE

Incorrect slip clutch torque settings may cause damage to the cutter and/or tractor. Be sure to retighten the nuts to their original position.

Note: Check each clutch periodically during the first hour of operation for excessive heat build-up due to unexpected slippage.

9.10 SLIP CLUTCH ADJUSTMENT

The slip clutches are factory preset to the correct torque for protecting the implement and tractor. Periodic adjustment is recommended. Should adjustment be needed, follow this procedure:

- Check to be sure all spring lengths are the same. Initial spring length is shown in the chart.
- If necessary, adjust the nut on any spring that is unequal. Adjust all eight spring retaining nuts 1/3 of a turn (two flats on a nut) and check clutch slippage.
- If further adjustment is necessary, adjust in 1/3 turn increments. Adjust only to provide sufficient torque to prevent slippage under normal conditions. Occasional slippage is normal for drivetrain protection. If satisfactory results cannot be obtained, consult your authorized dealer.

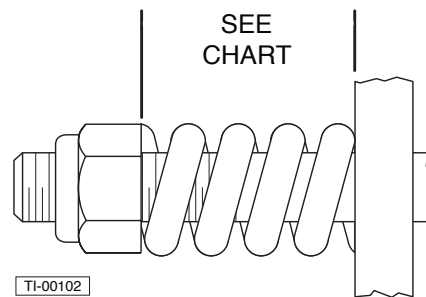

CLUTCH SPRING LENGTH CHART	
EG / COMERV	BONDIOLI & PAVESI.
1.27" (32.2mm)	1.15" (29.3mm)
1.28" (32.4mm)	1.12" (28.5mm)

NOTICE

Do not overtighten and cause the spring to become solid, as this will cause shaft failure.

9.11 SLIP CLUTCH DISASSEMBLY/ASSEMBLY

If the clutch did not slip during the operational check, it will need to be disassembled to separate the clutch plates from the friction discs.

1. Measure and record the compressed (assembled) spring length. This dimension will be needed for reassembly.
2. Remove spring retainer nuts (1), springs (2), and bolts (3).
3. Separate each friction disc (4) from the clutch plate next to it. Keep the parts in order, so that they can be reassembled in the same order.
4. Clean and inspect all parts. If the clutch has been slipped to the point of “smoking”, the friction discs should be replaced.

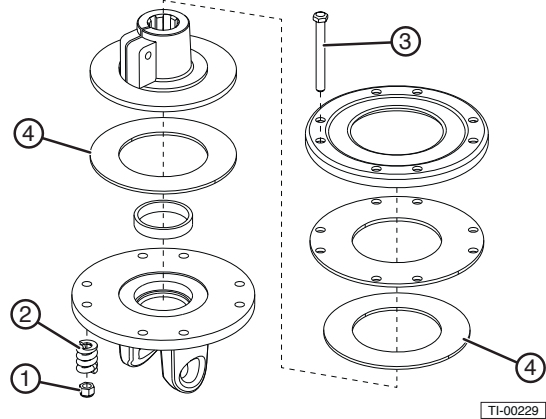

5. Reassemble each friction disc (4) next to the same clutch plate it was removed from. Make certain all bushings are replaced in the same location they were removed from. Install bolts (3) through the end plates and intermediate plates as shown. Place springs (2) over each bolt and secure with nuts (1).
6. Tighten each nut until the original spring length is attained. If the original length was not recorded, use the spring length from the chart in “9.10 Slip Clutch Adjustment” on page 54.

9.12 SLIP CLUTCH RUN-IN PROCEDURE

If a clutch is being rebuilt (new facing and/or plates), it is necessary to “run-in” these parts prior to final adjustment. The plates should be thoroughly cleaned and free of foreign material, as well as being checked for warping with a straight edge. Warped plates cannot be adjusted properly and will not hold. To accomplish the “run-in” after assembly, follow this procedure:

1. Tighten all the adjusting bolts evenly until the clutch cannot be slipped by hand.
2. With the blade carrier locked in a stationary position, operate with the PTO at idling speed (approximately 100 RPM), until evidence of heating is noted. **Do not allow the clutch to overheat.**
3. Discontinue operation and **allow the clutch to cool completely.**
4. After the clutch has cooled, tighten all the adjusting bolts evenly and proceed with the regular clutch adjusting procedures.

9.13 BOLT TORQUE REQUIREMENTS

It is extremely important to apply and maintain proper torque on all bolts. Use a torque wrench to ensure the proper amount of torque is being applied to the fastener.

Start all bolts or nuts by hand to prevent cross-threading.

Torque figures indicated in the chart are used for non-greased or non-oiled threads unless otherwise specified. Therefore, do not grease or oil bolts or cap screws unless otherwise specified in this manual.

When using locking elements, increase torque values by 5%.

The chart gives correct torque values for various bolts and cap screws. Tighten all bolts to the torque specified in the chart unless otherwise noted. Check tightness of bolts periodically, using the bolt torque chart as a guide. Always replace hardware with the same Grade bolt.

STANDARD TORQUE VALUES

Bolt Diameter	English Bolt Torque Specifications					
	Grade 2		Grade 5		Grade 8	
	N·m	ft.lbs.	N·m	ft.lbs.	N·m	ft.lbs.
1/4"	8	6	12	9	17	12
5/16"	13	10	25	19	36	27
3/8"	27	20	45	33	63	45
7/16"	41	30	72	53	100	75
1/2"	61	45	110	80	155	115
9/16"	95	60	155	115	220	165
5/8"	128	95	215	158	305	220
3/4"	225	165	390	290		398
7/8"	230	170	570	420	880	650
1"	345	225	850	630	1320	970



WARNING EQUIPMENT FAILURE



The torque value for bolts and cap screws is identified by their head markings. Replacing higher "Grade" bolts (Grade 5) with lower Grade bolts will lead to equipment failure and can result in injury or death. Always use replacement bolts with the same Grade markings as the removed bolt.

9.14 SERVICE RECORD

The period recommended is based on normal operating conditions. Severe or unusual conditions may require more frequent service. Copy this page to continue record.

Hours and Serviced By																				
Maintenance																				
Every 8 Hours																				
Make sure blade bolts are tightened to proper torque. Refer to "9.6.2 Blade Installation" on page 46.																				
Make sure all retainer clips and cotter pins are in place.																				
Inspect the cutting blades for wear and damage. Refer to "9.6.3 Blade Sharpening" on page 46.																				
Grease the driveline CV joint, U-joints, and slip joints. Refer to "9.5 Driveline Lubrication" on page 45.																				
Every 50 Hours																				
Check blade carrier nut torque. Refer to "9.6.2 Blade Installation" on page 46.																				
Grease all lubrication points. Refer to "9.3 Greasing" on page 44.																				
Annually																				
Grease all lubrication points. Refer to "9.3 Greasing" on page 44.																				
Make sure all fasteners are properly tightened.																				
Check cutter deck, gearboxes, and driveline for damage.																				
Inspect the cutting blades for wear and damage. Refer to "9.6.3 Blade Sharpening" on page 46.																				
Make sure the hitch pivot bolts and hitch pin are in good condition. Do not use homemade or shop made pins.																				
Make sure the slip clutches are functioning properly. Refer to "9.9 Slip Clutch Operational Check" on page 47.																				
Inspect the hitch and clevis for wear and damage.																				
Wash the rotary cutter.																				

TROUBLESHOOTING

PROBLEM	CAUSE	SOLUTION
Uneven cut.	Excessive ground speed.	Reduce ground speed.
	Blades worn, dull, or bent.	Replace blades.
	Improper height adjustment.	Adjust rotary cutter height. Refer to "6.4.2 Setting the Cutting Height" on page 34.
	Low tractor tire pressure on one side.	Adjust tire pressure. (Refer to OEM manual).
	Turning too fast.	Reduce ground speed when turning.
	Tractor tires pushing grass down.	Adjust your tractor wheel spacing. (Refer to OEM manual).
	Damaged cutter pan.	Repair or replace as necessary.
Uncut material.	Excessive ground speed.	Reduce ground speed.
	RPM too low.	Maintain rated PTO RPM.
Windrowing.	Material heavy and lush.	Raise the front of rotary cutter relative to the rear. Refer to "6.4 Setting the Rotary Cutter" on page 33.
	Excessive ground speed.	Reduce ground speed.
	Conditions too wet.	Wait for conditions to dry. Reduce ground speed.
Grass cut lower in center of swath than at edge.	Height of rotary cutter lower at rear or front.	Adjust rotary cutter height and attitude so that rear and front are within 1/2" of same height.
Streaking conditions in swath.	Blades dull.	Sharpen or replace blades.
	Blades unable to cut that part of grass pressed by path of tractor tires.	Slow ground speed of tractor but maintain rated PTO RPM. Cutting lower will help.
	Conditions too wet for mowing.	Allow grass to dry before mowing.
Material discharges from cutter unevenly; bunches of material along swath.	Material too high and too much material.	Reduce ground speed but maintain rated tractor PTO RPM or make two passes over material. Raise rotary cutter for the first pass and lower to desired height for the second and cut at 90° to first pass. Raise rear of rotary cutter high enough to permit material to discharge but not so high as to cause conditions listed above.
	Grass wet.	Allow grass to dry before mowing. Reduce ground speed but maintain rated tractor PTO RPM.
	Rear of rotary cutter too low, trapping material under cutter.	Adjust rotary cutter height and attitude.
Rotary cutter will not cut all the time.	Slip clutch slipping.	Adjust slip clutch. Refer to "9.10 Slip Clutch Adjustment" on page 47.
	Burnt or damaged clutch facing.	Rework clutch or replace according to OEM manual.
Blade bolts working loose.	Bolts not tightened.	Tighten bolts. Refer to "9.6 Blade Servicing" on page 45.
	Bolt hole elongated or oversized.	Replace blade carrier. Refer to "9.7 Blade Carrier Removal" on page 47.
	Lockwasher broken.	Replace lockwasher. Refer to "9.6 Blade Servicing" on page 45.
Gearbox noisy.	Low lubricant level.	Add grease. Refer to "9.4 Gearbox Lubrication" on page 45.
	Worn bearing.	Replace bearing.
Gearbox overheating.	Low on lubricant.	Fill to level plug.
	Improper type of lubricant.	Replace with proper lubricant. Refer to "9.4 Gearbox Lubrication" on page 45.
	Excessive trash build-up around gearbox.	Remove trash.

Gearbox leaking.	Damaged oil seal.	Replace seal.
	Bent shaft.	Replace gearbox.
	Oil seal not sealing in the housing.	Replace seal or use a sealant on O.D. of seal.
	Oil level too high.	Drain to proper level.
	Gasket damaged.	Replace gasket.
	Bolts loose.	Tighten bolts.
Excessive vibration.	Blades are not free to swing.	Check bushing and blade movement.
	Blades are out of balance.	Check blades for damage or replace blades. Refer to "9.6 Blade Servicing" on page 45.
Unusual noise.	Loose blade bolts or worn bushings.	Tighten bolts, check bushings for wear and change as needed. Refer to "9.6 Blade Servicing" on page 45.
	Bent blade carrier or blades.	Replace blade carrier or blades. Refer to "9.7 Blade Carrier Removal" on page 47.
	Deck bent, causing blades to contact deck.	Straighten deck.
Driveline will not telescope.	Improper lubrication.	Grease driveline. Refer to "9.5 Driveline Lubrication" on page 45.
	Driveline twisted.	Replace driveline. Caution operator not to strike ground with blades.
	Driveline bent.	Driveline too long. Replace and shorten to proper length. Refer to "5.5 Shortening the Driveline" on page 29.
	Shields damaged.	Replace shields.
Driveline U-joint failing.	Lack of lubrication.	Grease U-joint zerks every 8 hours. Refer to "9.5 Driveline Lubrication" on page 45.
Driveline twisted.	Over torqued.	Replace driveline. Caution operator not to strike ground with blades.
	Not maintaining correct PTO speed.	Maintain rated PTO RPM.
Slip clutches slip under light load.	Slip clutch is not properly adjusted.	Adjust slip clutch. Refer to "9.10 Slip Clutch Adjustment" on page 47.
	Clutch plates are worn out.	Replace clutch plates.
	Debris is caught between the clutch plates.	Remove debris.

LIMITED WARRANTY

IronCraft (the Manufacturer) warrants, only to the original Purchaser, this equipment will be free from defects in material and workmanship, under normal use and service, for one (1) year from the date of purchase providing this equipment is purchased for individual use only. **Commercial use of this equipment is not covered under any warranty.** This warranty does not apply to any equipment which has been damaged or which has been subjected to change, misuse, negligence, abnormal wear and tear, alterations, tampering, or failure to follow operating instructions. This warranty does not cover any product or parts not manufactured by IronCraft.

IronCraft rotary cutters have a five (5) year Limited Warranty* on gearbox components provided they have been properly maintained** and have not been subjected to abuse or misuse except as limited below.

*** Gearbox warranty limitations:**

- i. Warranty is one (1) year for seals unless seals are damaged from debris wrapped around the input and or output shaft of the gearbox. After one year, seals are considered to be wearing parts, and the replacement is the owner's responsibility.
- ii. Gearboxes that are subject to warranty may be replaced with new or rebuilt gearboxes at the discretion of IronCraft
- iii. **Shearbolts must be approved Grade 2 , 1 /2 “ x 3 “ shearbolts.**

****NOTE : “properly maintained” specifically includes, but is not limited to:**

- i. Running gearboxes with the proper amount of correct lubricant.
- ii. Adjusting slip clutches correctly to provide proper protection for gearbox components and drive line.

Under this warranty, the Manufacturer will repair or replace any part which the Manufacturer determines has failed during the period of the warranty due to defects in material or workmanship. After written approval by the manufacturer, the equipment or defective part must be returned to IronCraft.

Warranty coverage and performance is expressly conditioned upon the return of the completed registration form to:

IronCraft, 7 Rocky Mt Rd, Athens, Tennessee 37303. Registration can be found on our website www.ironcraftusa.com

IronCraft reserves the right to make improvements and changes in specifications without notice or obligation to modify previously sold units. The Owner's Manual describes the proper assembly procedures for your implement and furnishes operating and maintenance recommendations to help you obtain long and satisfactory service.

PURCHASER'S EXCLUSIVE REMEDY FOR BREACH OF WARRANTY, OTHER DEFECT, OR CONDUCT GIVING RISE TO LIABILITY SHALL BE THE REPAIR OR REPLACEMENT OF THE PRODUCT SOLD, AND THE MANUFACTURER UNDER NO CIRCUMSTANCES SHALL BE LIABLE FOR ECONOMIC LOSS OR INCIDENTAL OR CONSEQUENTIAL DAMAGES. THE MANUFACTURER DISCLAIMS ALL IMPLIED WARRANTIES, INCLUDING THE WARRANTY OF MERCHANTABILITY AND FITNESS FOR PURPOSE.

Purchaser and IronCraft hereby (a) submit to the non-exclusive jurisdiction of the courts of competent jurisdiction in Meigs County, Tennessee, and the United State District Court for the Eastern District of Tennessee for resolution of any dispute concerning this Limited Warranty or the rights or obligations of Purchaser and/or IronCraft; (b) agree that any litigation commenced in Tennessee in connection with this Limited Warranty shall be venued in either the Meigs County, Tennessee District Court, or the United States District Court, Eastern District of Tennessee, Southern Division, and (c) waive any objection it may have as to any such action or proceeding brought in such court that such court is an inconvenient forum. Nothing herein shall limit the right of Purchaser or IronCraft (or the right of any permitted successor or assign of either) to bring proceedings against the other in the courts of any other jurisdiction wherein any assets of such other party may be located.

REGISTER

This registration form must be filled out within 30 days of delivery to the purchaser or future warranty claims will not be honored.



www.ironcraftusa.com/warranty/register-warranty/

MAKE CLAIM

This form is for dealer use only. Do not use for warranty labor or parts reimbursement.



www.ironcraftusa.com/warranty/claim-warranty/

REIMBURSEMENT

This form is for dealer use only. Apply for warranty labor or parts reimbursement here.



<https://www.ironcraftusa.com/warranty/reimbursement-form/>

www.ironcraftusa.com/warranty/claim-warranty/

PARTS

Replacement parts are available from your authorized Dealer Parts Department or from IronCraft.
The following pages contain a list of serviceable parts for the IronCraft 2512 flex-wing rotary cutter.

12.1 A-FRAME COMPONENTS

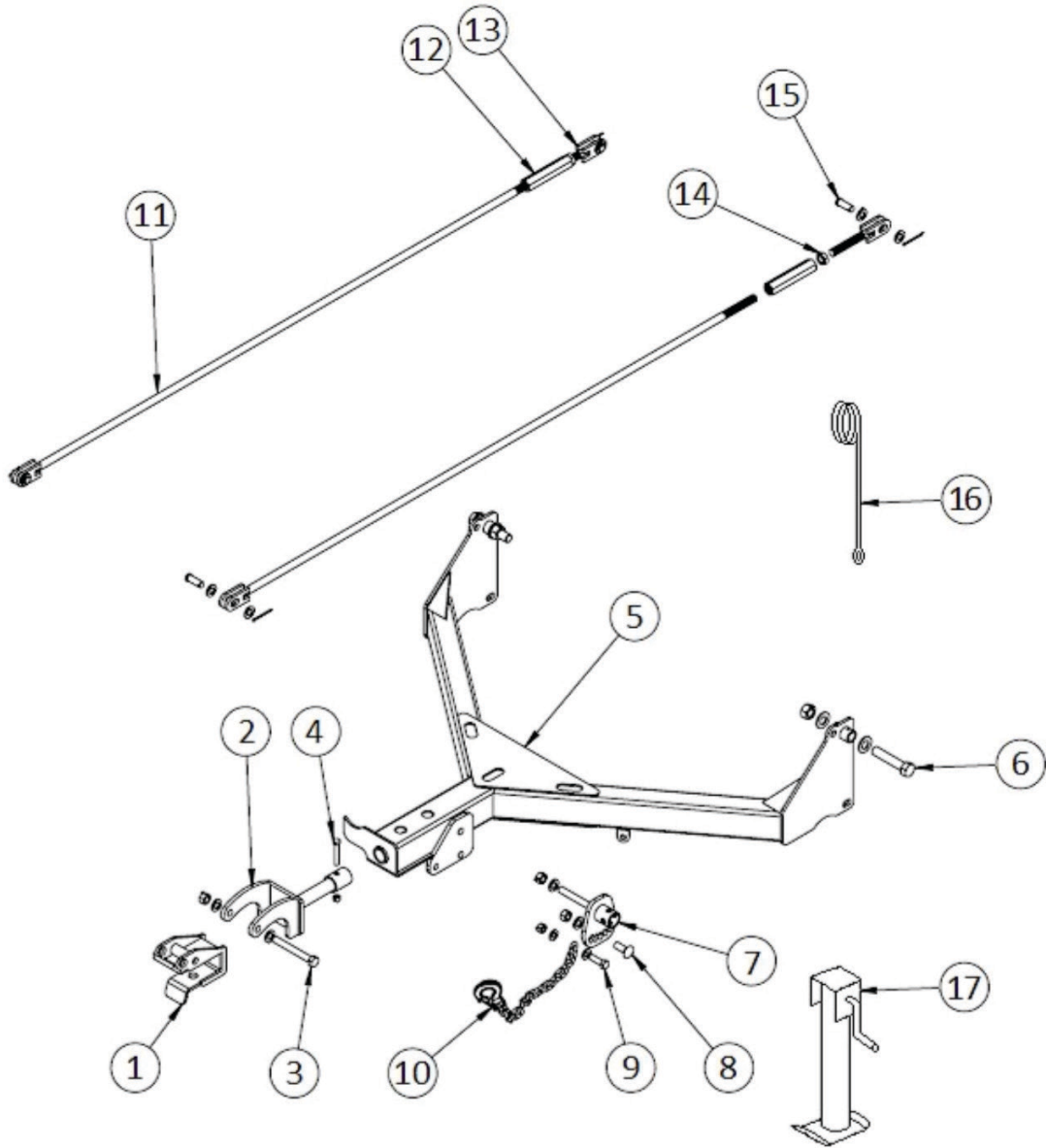

A-FRAME COMPONENTS			
ITEM	PART #	DESCRIPTION	QTY
1	200016-BK	Clevis Hitch – Weldment	1
2	200020-BK	Receiveing Hitch – Weldment	1
	2050005	Swivel Lock Collar	1
3	150047	Bolt Kit 3/4" X 6" W/Flatwasher & Locknut	1
4	191213	Swivel Bolt Kit 1/2" X 2-1/2" W/Locknut	1
5	200047-BK	A-Frame Hitch – Weldment	1
6	920006	Bolt Kit 1" X 4-1/2" W/Flatwasher & Locknut	2
7	300027-BK	Jack Lug – Weldment	1
8	120011	Carriage Bolt Kit 1/2" X 1-1/2" W/Locknut	1
9	110071	Botl Kit 5/8" X 2-1/2" W/Locknut	1
10	191526	Safety Chain	1
11	200049-BK	Long Leveling Rod 57"	2
12	191229	Leveling Rod Adjuster	2
13	200023-BK	Short Leveling Rod	2
14	351508	Jam Nut 7/8"	2
15	351509	Clevis Pin W/Flatwashers & Cotter Pin	4
16	191209	Spring – Hose Holder	1
17	180024	Jack Stand	1

12.2 CENTER DECK COMPONENTS

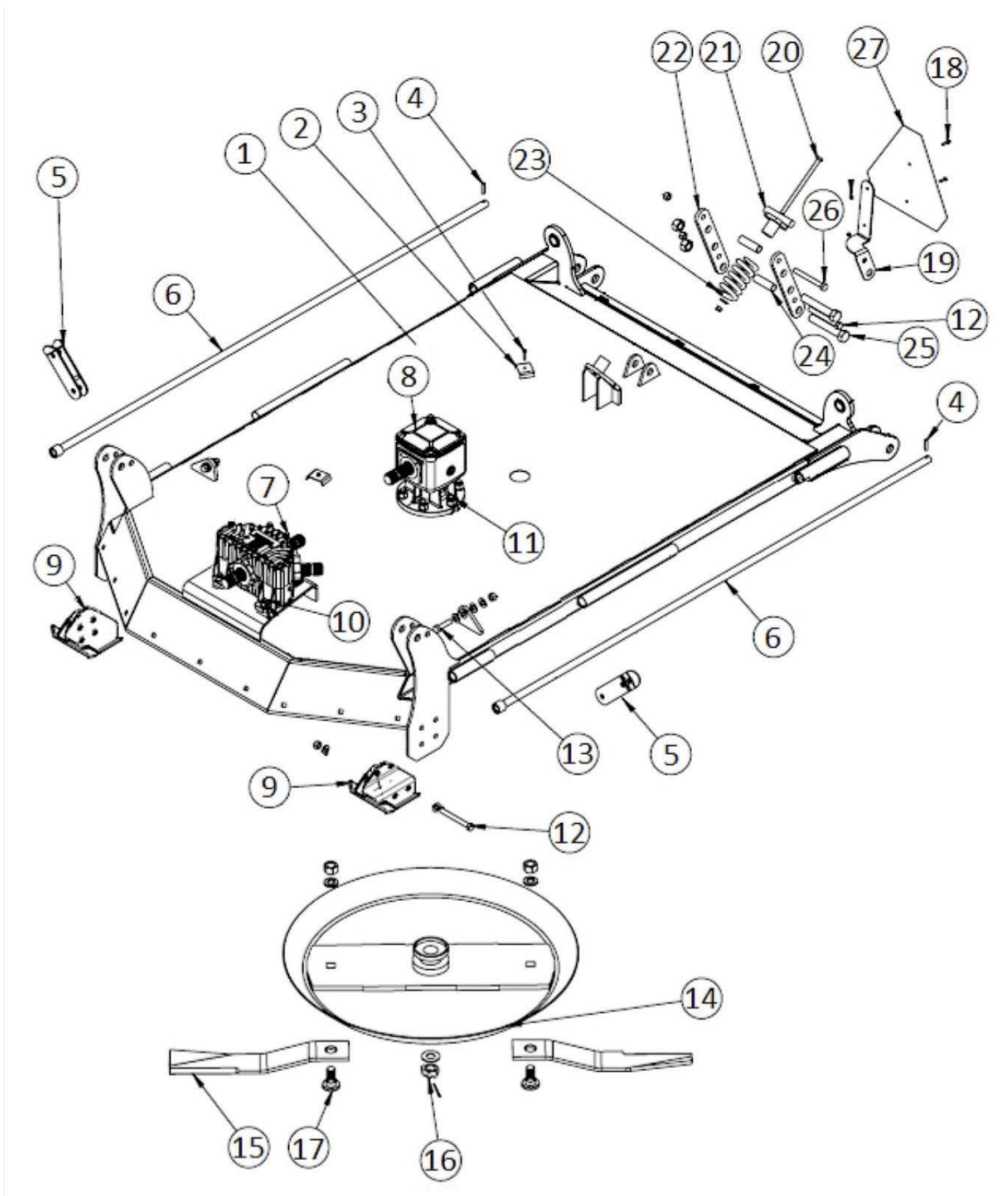

CENTER DECK COMPONENTS			
ITEM	PART #	DESCRIPTION	QTY
1	201030	Center Deck – Weldment (Specify Color)	1
2	3010111-BK	Hose Holder	2
3	351511	Self-Tapping Screw 1/4" X 1-1/2"	2
4	351510	Roll Pin 3/8" X 1-3/4"	2
5	200017-BK	Deck Lock – Weldment	2
6	200055	Hinge Rod 1" X 62-3/4"	2
7	191501	Splitter Gearbox – 540 Rpm	1
8	191304	Center Gearbox – 540 Rpm	1
9	201033-BK	LH – Front Center Skid Shoe	1
	201032-BK	Rh – Front Center Skid Shoe	1
10	110004	Bolt Kit 5/8" X 2" Bolts W/ Locknuts (4-Pack)	1
11	610030	Bolt Kit 3/4" X 2-1/2" Bolts W/Locknuts (6-Pack)	1
12	610004-KIT	Bolt Kit 5/8" X 2-1/2" Bolt W/Locknut	8
13	610004-KIT	Bolt Kit 5/8" X 2-1/2" Bolt W/Locknut	2
14	200046-BK	Blade Carrier	1
15	T-60	Blades (Sold As Pair)	1
16	191341	Castle Nut M24 X 2	1
	191340	Flatwasher 25 X 44 X 4	1
	191342	Cotter Pin 5 X 50	1
17	110012	Blade Bolt Kit – W/Nut & Lw (Sold As Pair)	1
18	351518	Bolt Kit 1/4" X 1" Bolt W/Locknut	2
19	2010063-BK	SMV Sign Bracket	1
20	191219	Spring Bolt Kit 1/2" X 9" Bolt W/Fw & Ln	1
21	200027-BK	Spring Mount Bracket	1
22	2010056-BK	Suspension Spring Bracket	2
23	191218	Suspension Spring .625" X 3.2"O.d. X 6"	1
24	191223	Bracket Bolt Spacer 3.5"	2
25	191224	Spring Arm Bolt Kit 1" X 6" Bolt W/Locknut	2
26	191222	Spring Brkt. Bolt Kit 5/8" X 5-1/2" Bolt W/Fw & Ln	1
27	191651	SMV Kit	1

12.3 CENTER SHIELD COMPONENTS

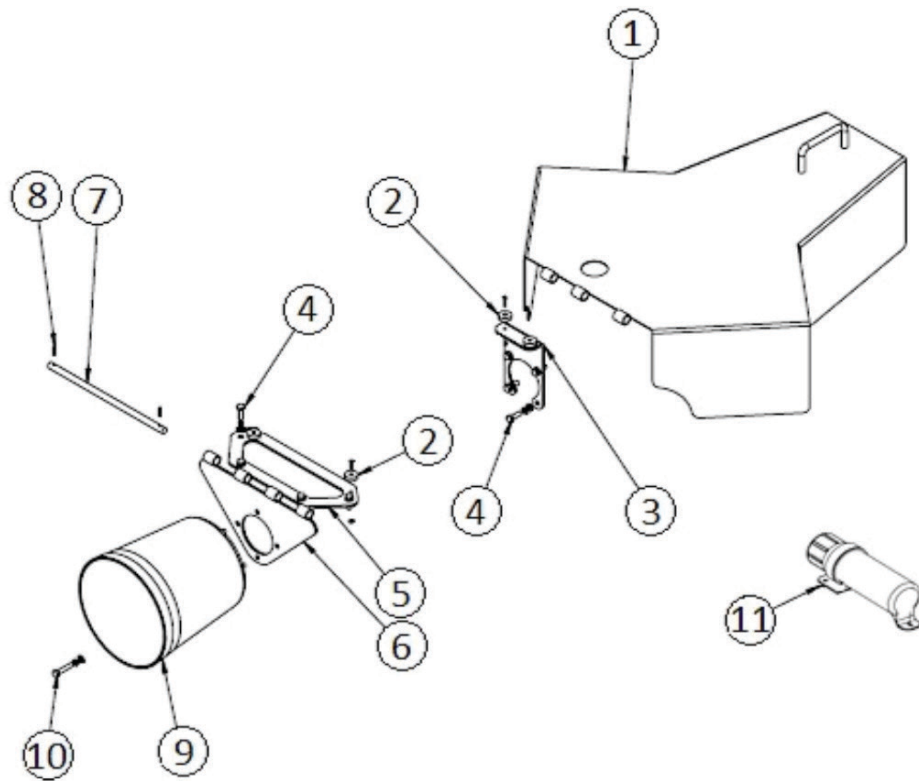

CENTER SHIELD COMPONENTS			
ITEM	PART #	DESCRIPTION	QTY
1	200044-BK	Splitter Gearbox Shield	1
2	83070000	Magnet Kit 6-32 X 3/4" CSK Bolt & Locknut	4
3	2010104-BK	Center-Gearbox Magnet Mount	1
4	351521	Bolt Kit M8 X 25 Bolt W/FW & Nuts (8-Pack)	1
5	3010112-BK	Splitter-Gearbox Magnet Mount	1
6	300016-BK	Center Shield Mount	1
7	3030001	Center Shiled Hinge	1
8	111002	Roll Pin 3/16" X 3/4"	2
9	120001	Gearbox Shield (Plastic)	1
10	111001	Bolt Kit M8 X 40 Bolt W/LW & FW (4-Pack)	1
11	110034	Manual Holder	1

12.4 DRIVELINE & SHIELD COMPONENTS

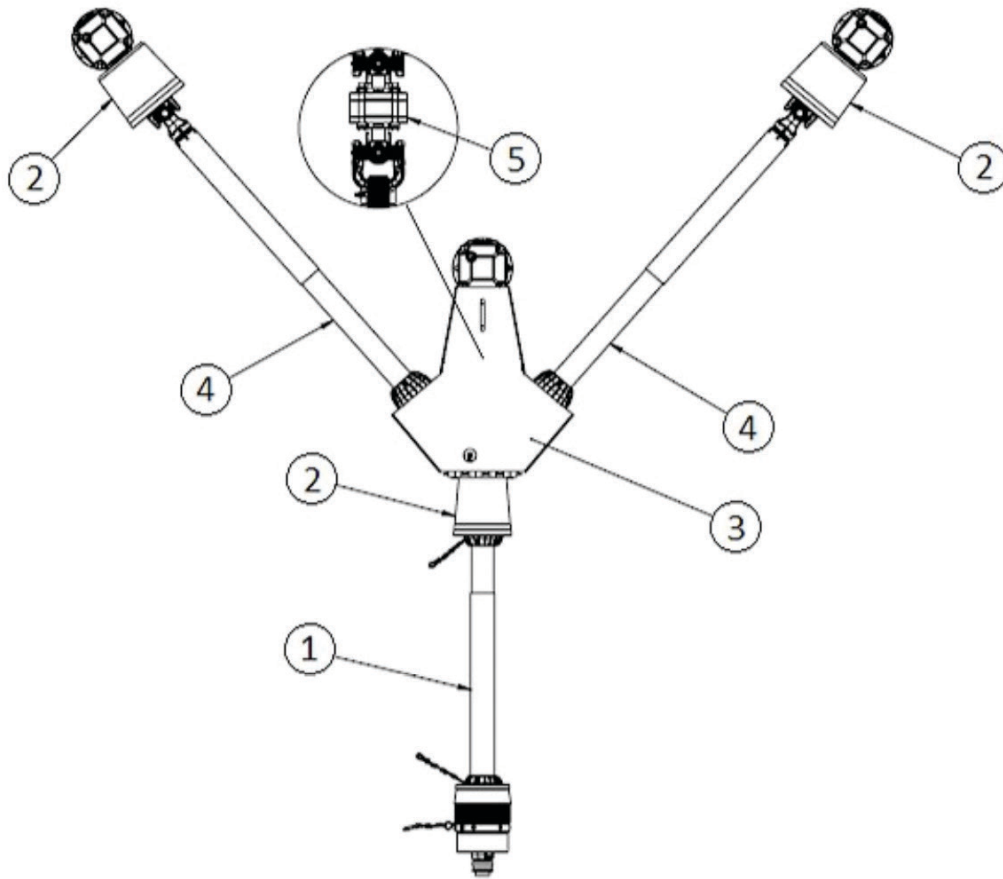

DRIVELINE & SHIELD COMPONENTS			
ITEM	PART #	DESCRIPTION	QTY
1	191255	C.V. Driveline S6CVE-1321	1
2	120001	Gearbox Shield (Plastic)	1
3	200044-BK	Splitter Gearbox Shield	1
4	191254	Wing Driveline S507CLE-1316	2
5	191203	Cross Shaft S4ECL-366	1

12.5 WING DECK COMPONENTS

Parts list encompasses left and right wing. Left wing shown.

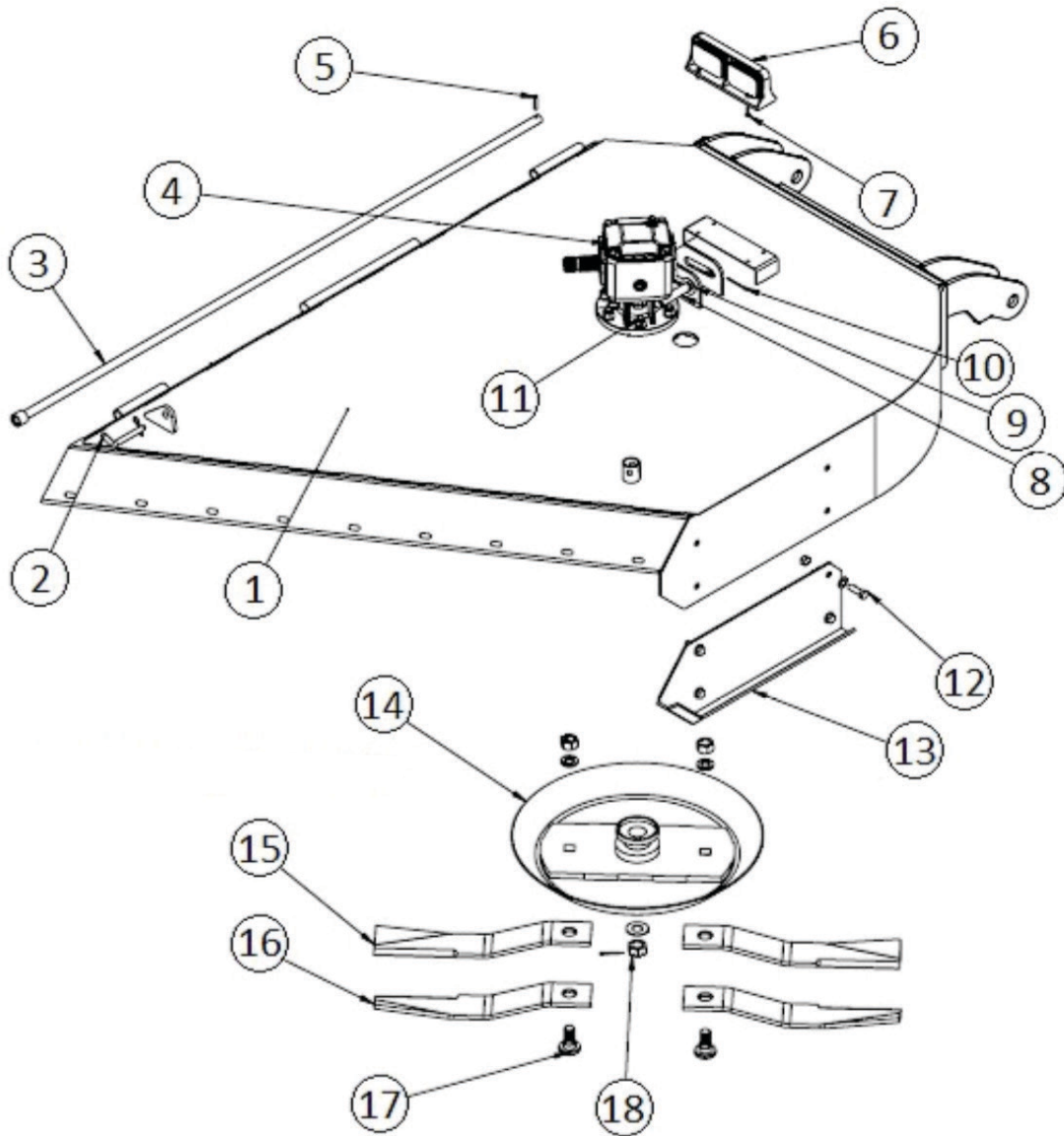

WING DECK COMPONENTS			
ITEM	PART #	DESCRIPTION	QTY
1	200036	Lh Wing Deck – Weldment (Shown)	1
	200041	Rh Wing Deck – Weldment	A/R
2	83030010	Bent Pin 5/8" W/R-Clip	1
3	200055	Hinge Rod 1" X 62-3/4"	1
4	191304	Lh Gearbox 540-Rpm	1
	191306	Rh Gearbox 540-Rpm	A/R
5	351510	Roll Pin 3/8" X 1-3/4"	2
6	191650	Caution Light Kit	1
7	351516	Bolt Kit 1/4" X 1" Bolt W/Locknut	4
8	83030009	Clevis Pin 1"	1
9	81000017	Flatwasher 1" Sae	2
10	351514	Cotter Pin 1/8" X 2"	2
11	610030	Bolt Kit 3/4" X 2-1/2" Bolt W/Lock Nut (6-Pack)	1
12	110004	Bolt Kit 5/8" X 2" Bolt W/Locknut (4-Pack)	1
13	200018-BK	Lh Wing Skid (Shown)	1
	200021-BK	Rh Wing Skid Shoe	A/R
14	200046-BK	Blade Carrier	1
15	T-48	Rh-Ccw Blade (Sold As Pair)	A/R
16	T-48R	Lh-Ccw Blade (Sold As Pair)	1
17	110012	Blade Bolt Kit W/Nut & Lw (Sold As Pair)	1
18	191341	Castle Nut M24 X 2	1
	191340	Flatwasher 25 X 44 X 4	1
	191342	Cotter Pin 5 X 50	1

Parts list encompasses left and right wing. Left wing shown.

A/R = As Required

* Specify Color

12.6 WHEEL LIFT COMPONENTS

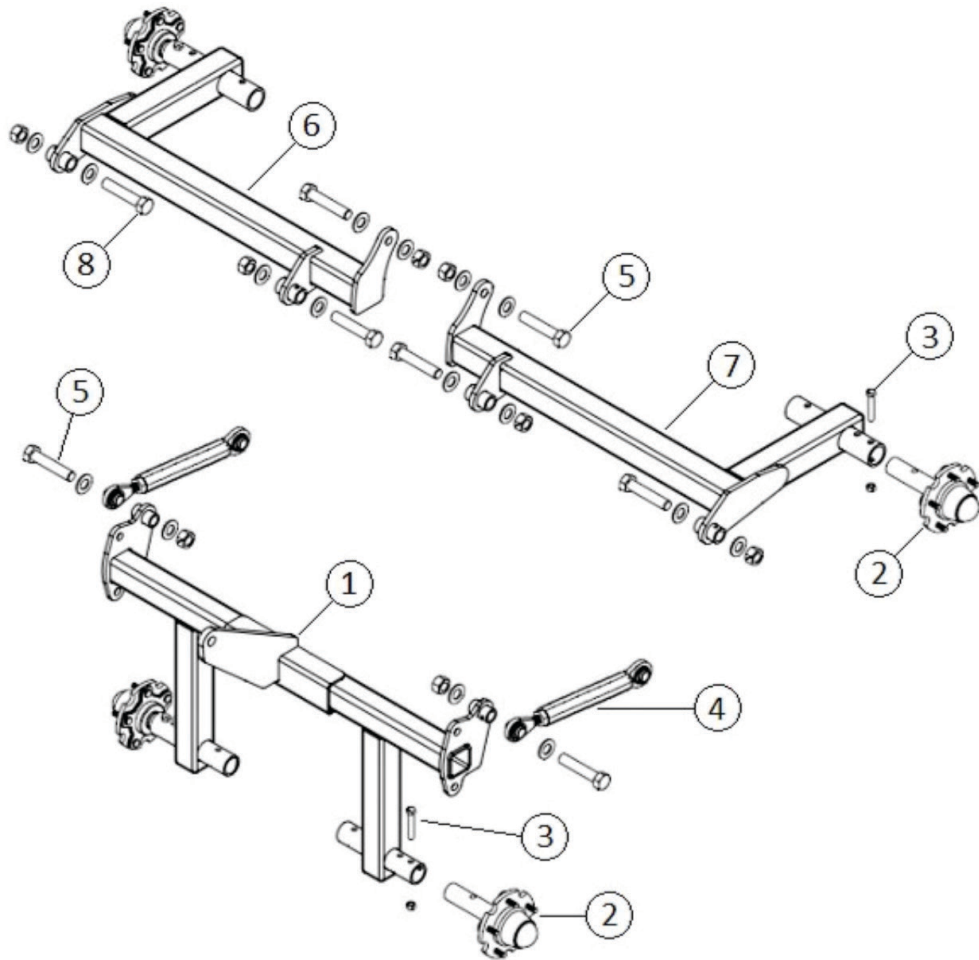

WHEEL LIFT COMPONENTS			
ITEM	PART #	DESCRIPTION	QTY
1	201034-BK	Center Wheel Lift – Weldment	1
2	351522	Hub/Spindle Assembly	6
3	180039	Spindle Bolt Kit 1/2" X 3-1/2" Bolt W/Locknut	6
4	191231	Turnbuckle	2
5	110071	Bolt Kit 5/8" X 2-1/2" Bolt W/Flatwashers & Ln	4
6	200043-BK	RH Wing Wheel Lift – Weldment	1
7	200040-BK	LH Wing Wheel Lift – Weldment	1
8	920006	Bolt Kit 1" X 4-1/2" Bolt W/Flatwashers & Ln	6

12.7 WHEEL OPTIONS

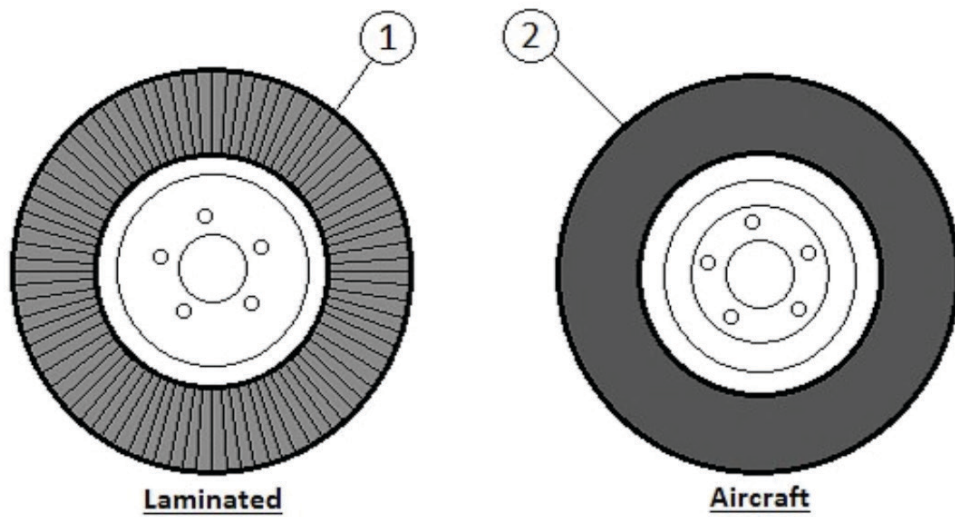

WHEEL OPTIONS			
ITEM	PART #	DESCRIPTION	QTY
1	180040	Laminated Wheel 20"	A/R
2	191380	Aircraft Tire 22"	A/R

A/R = As Required

12.8 HYDRAULIC COMPONENTS

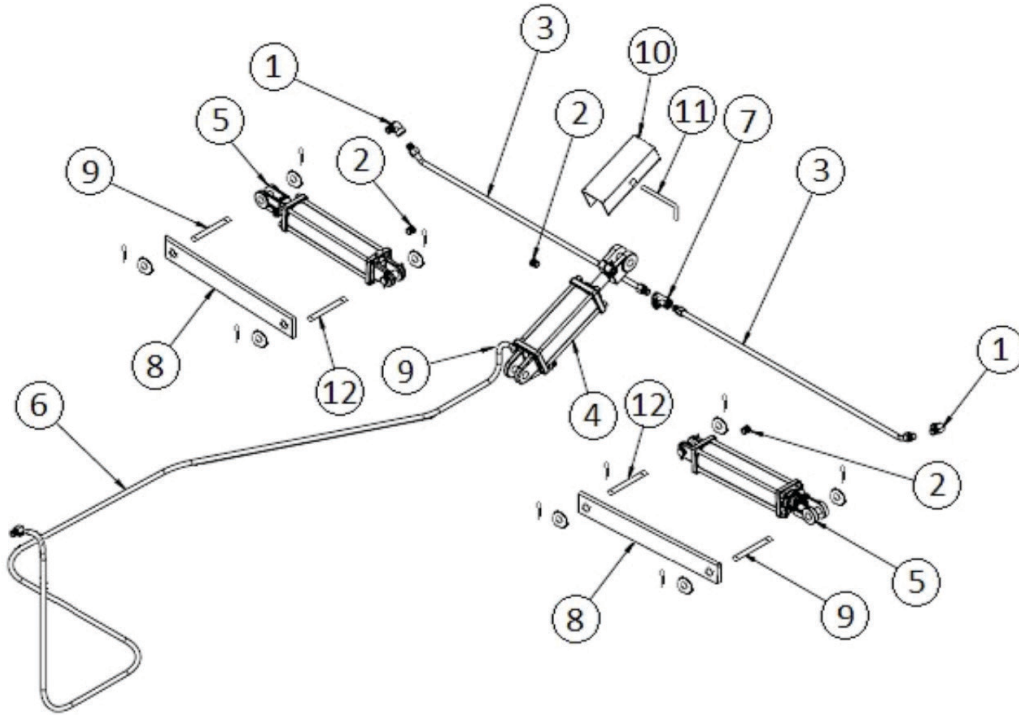

HYDRAULIC COMPONENTS			
ITEM	PART #	DESCRIPTION	QTY
1	920083	Elbow 8mp-6mj	A/R
or	920095	Elbow 6mj-6mp90	A/R
2	191281	Breather 8-Nptm	1
3	191236	Hyd. Hose 1/4" X 57"	2
4	191225	Center-Transport Cylinder 2-1/2" X 8"	1
5	191226	Wing Cylinder 2" X 8" Asae	2
6	191237	Hyd., Hose 1/4" X 168"	1
7	191238	Tee Fitting 6mj-6mj-6mp	1
8	191227	Wing Lock Bar	2
9	191240	Outside Cylinder Pin 1" X 5-1/2"	2
10	191531-BK	Cyl. Transport Lock	1
11	310034	L-Shaped Pin 1/2"	1
12	191539	Inside Wing Cyl. Pin 1" X 5"	2

A/R = As Required

12.9 CHAIN GUARD COMPONENTS

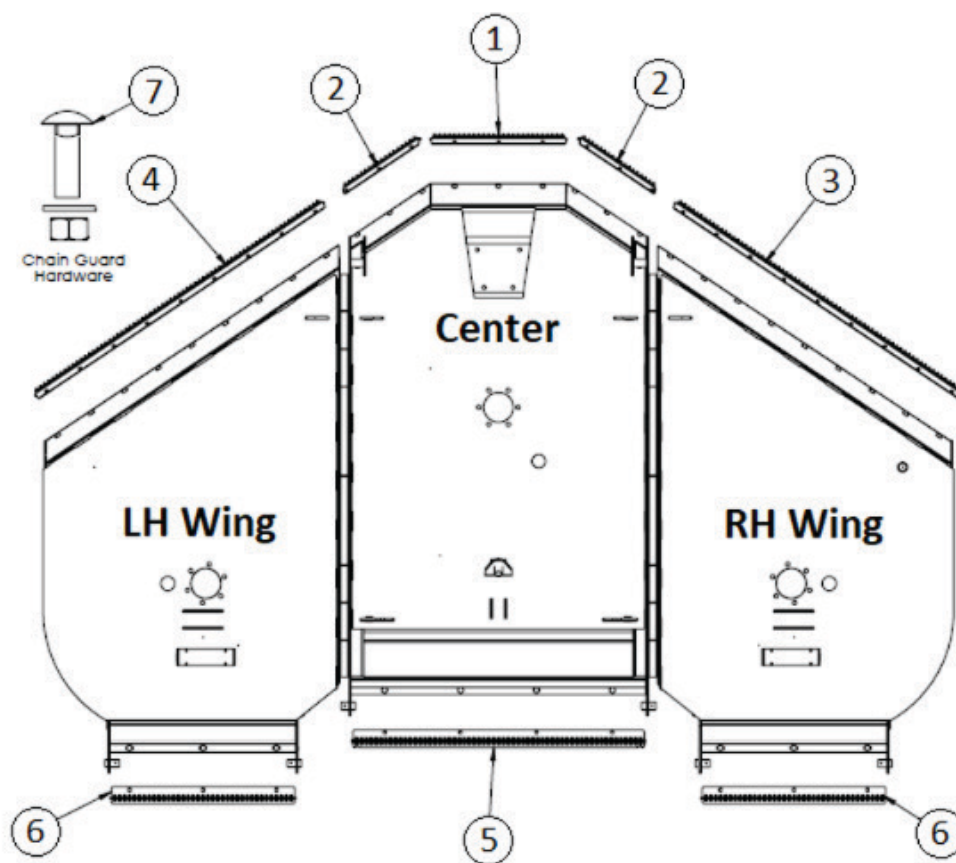

CHAIN GUARD COMPONENTS			
ITEM	PART #	DESCRIPTION	QTY
1	CG-19121	Center Deck Front Chain Shield Assembly	1
2	CG-19122	Center Deck Front Lh Chain Shield Assembly	1
	CG-19127	Center Deck Front Rh Chain Shield Assembly	1
3	CG-19123	Lh Wing Deck Front Chain Shield Assembly	1
4	CG-19124	Rh Wing Deck Front Chain Shield Assembly	1
5	CG-19125	Center Deck Rear Chain Shield Assembly	1
6	CG-19126	Lh & Rh Rear Wing Deck Shield Assembly	2
7	191253	Carriage Bolt Kit 1/2" X1-1/2" (10-Pack)	A/R
	CG-19120	Complete Shield Kit	

A/R = As Required

12.10 COMER – 540/1000 RPM SPLITTER GEARBOX COMPONENTS

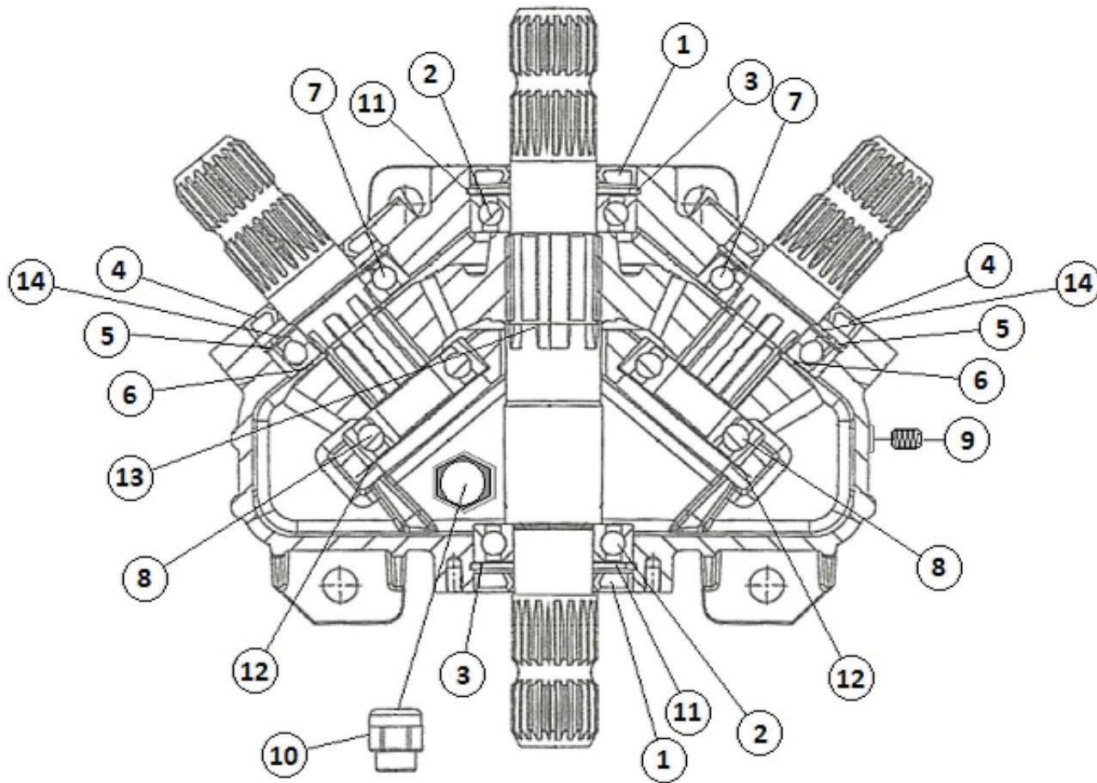

140 (ISO460)
Gearoil Recommended
Fill level 61-oz. (1.83-qt)

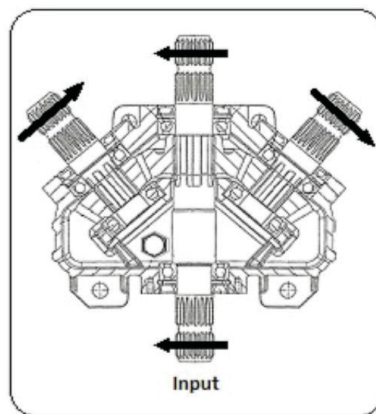

COMER – 540/1000 RPM SPLITTER GEARBOX COMPONENTS			
ITEM	PART #	DESCRIPTION	QTY
1	551060	Input Seal 45 X 85 X 10	2
2	551061	Input Bearing 6209 – Thru Shaft	2
3	551062	Snap Ring 85 X 88.5 X 3	2
4	551063	Output Seal 45 X 80 X 10	2
5	551064	Snap Ring 80 X 83.5 X 2.5	2
6	551065	Snap Ring 40 X 37.5 X 2.5	2
7	SK7033	Bearing 6208	2
8	SK1131	Bearing 6307	2
9	551068	Check Plug 3/8”	2
10	551069	Breather Plug 1/2”	1
11	551070	Shim Kit 70.3 X 84.7	2
12	551071	Shim Kit 69.0 X 79.9	2
13	551073	Snap Ring 47 X 45.5 X 1.5	1
14	551072	Shim Kit 65.3 X 79.7	2
	191501	Complete Gearbox 540-Rpm	
	191502	Complete Gearbox 1000-Rpm	

12.11 GTM – 540/1000 RPM SPLITTER GEARBOX COMPONENTS

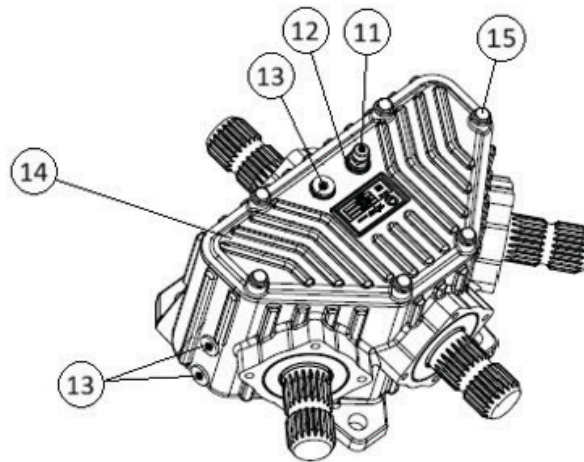
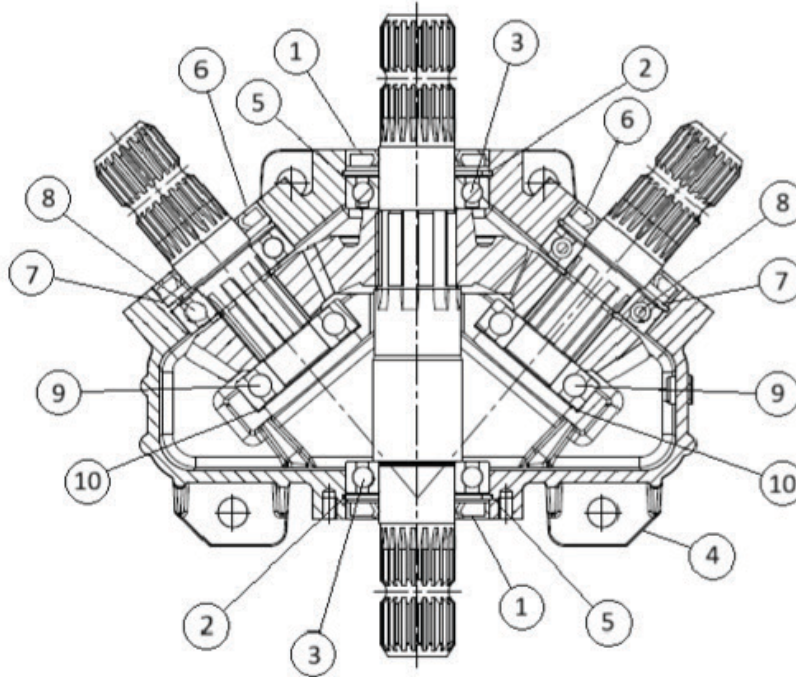

140 (ISO460)
Gearoil Recommended
Fill level 61-oz. (1.83-qt)

GTM 540/1000 SPLITTER GEARBOX COMPONENTS			
ITEM	PART #	DESCRIPTION	QTY
1	191350	Double Lip Oil Seal 45 X 85 X 10	2
2	191351	Snap Ring 85 X 3	2
3	191385	Ball Bearing 6209	2
4	N/A	Housing (Photo For Assembly References)	N/A
5	191386	Adj. Shim 84.5 X 73 X 0.5	2
	191395	Adj. Shim 84.5 X 73 X 0.1	5
6	191387	Double Lip Oil Seal 45 X 80 X 10	2
7	191388	Flatwasher 68 X 79.8 X 1	2
	191396	Adj. Washer 68 X 79.8 X 0.1	6
8	191389	Ball Bearing 6208	2
9	191390	Ball Bearing 6307	2
10	191391	Adj. Washer 68 X 79.8 X 0.5	2
	191397	Adj. Washer 68 X 79.8 X 0.3	4
11	191371	Vent Plug M16 X 1.5	1
12	191372	Washer For Plug 16.2 X 19.9 X 1.5	1
13	191392	Hex Pipe Plug 3/8-18npt	3
14	191393	Top Cover Plate	1
15	191394	Hh Flange Bolt W/Teeth M8 X 30	6
	191501	Complete Gearbox 540-Rpm	
	191502	Complete Gearbox 1000-Rpm	

N/A = Not Available

12.12 OUTBOARD GEARBOX COMPONENTS

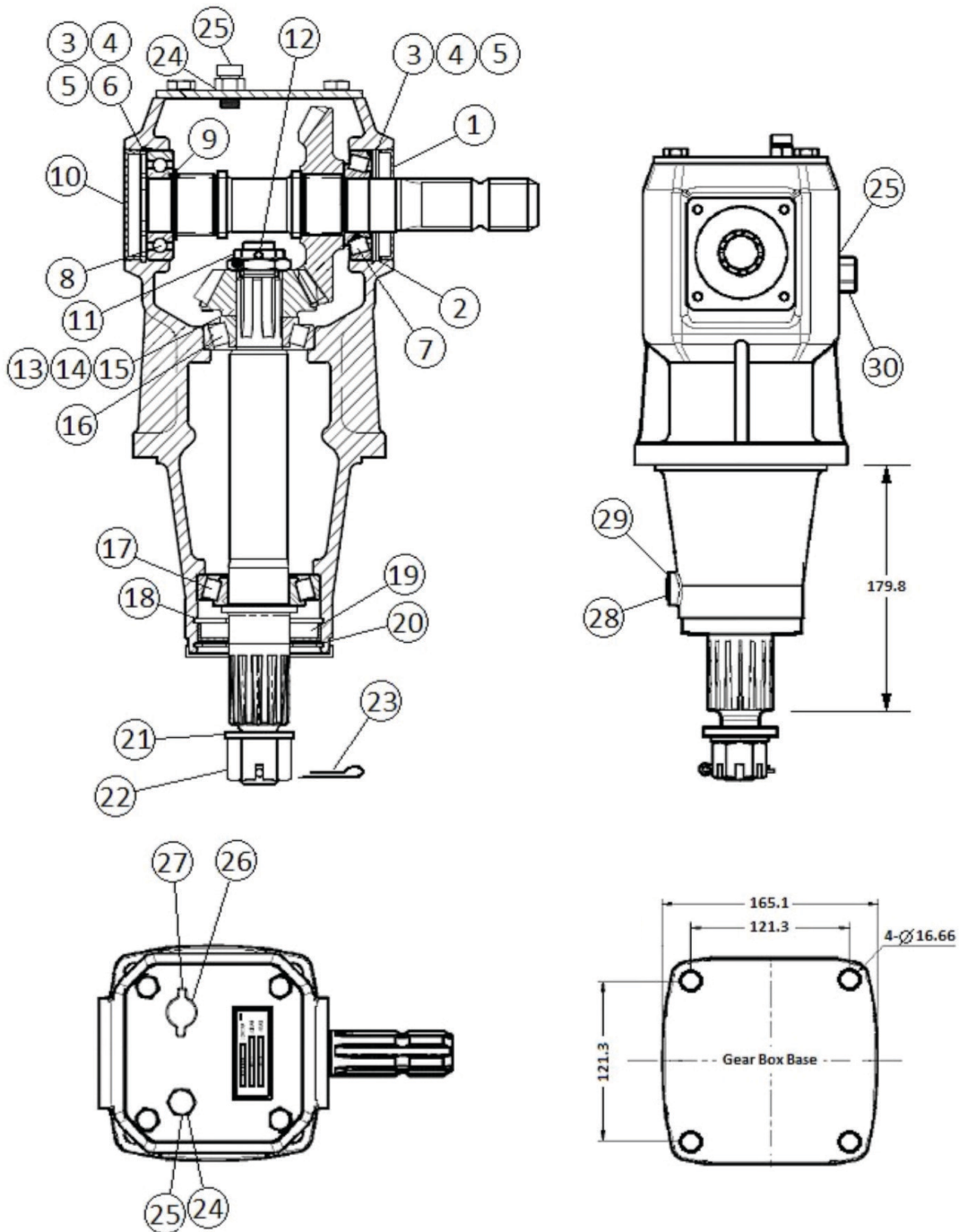

140 (ISO460)
Gearoil Recommended

Fill level 61-oz. (1.83-qt)

OUTBOARD GEARBOX COMPONENTS			
ITEM	PART #	DESCRIPTION	QTY
1	191320	Double Lip Seal 35 X 72 X 10	1
2	191321	Snap Ring 72 X 2.5	2
3	191322	Adj. Washer 62 X 71.8 X 0.1	2
4	191323	Adj. Washer 62 X 71.8 X 0.3	2
5	191324	Adj. Washer 62 X 71.8 X 0.5	2
6	191325	Adj. Washer 62 X 71.8 X 1	1
7	191326	Tapered Roller Bearing 30207	1
8	191327	Ball Bearing 6207	1
9	191328	Flatwasher 35.2 X 45 X 2	1
10	191329	Solid Oil Seal Plug 72 X 10	1
11	191330	Castle Nut M20 X 1.5	1
12	191331	Cotter Pin 4 X 40	1
13	191332	Adj. Washer 30.3 X 42 X 0.1	2
14	191333	Adj. Washer 30.3 X 42 X 0.3	1
15	191334	Adj. Washer 30.3 X 42 X 0.5	1
16	191335	Tapered Roller Bearing 30306	1
17	191336	Tapered Roller Bearing 30208	1
18	191337	Snap Ring 80 X 2.5	2
19	191338	Double Lip Seal 40 X 80 X 12	1
20	191339	Washer 40.1 X 79.9 X 1	1
21	191340	Flatwasher 25 X 44 X 4	1
22	191341	Castle Nut M24 X 2	1
23	191342	Cotter Pin 5 X 50	1
24	191343	Vent Plug M16 X 1.5	1
25	191344	Washer For Plug 16.2 X 19.9 X 1.5	2
26	191345	Sealed Washer – Oil Leveler	1
27	191346	Oil Leveler Ez40 M16 X 1.5	1
28	191347	Solid Plug 9/16"-18unf	1
29	191348	O-Ring 11.2 X 2	1
30	191349	Oil Plug M16 X 1.5	1
	191304	Center & Lh Wing Gearbox (Rg40-A)	
	191306	Rh Wing Gearbox (Rg40-O)	

Note: Production Models started using 02-22-21

12.13 CENTER DECK CROSS SHAFT COMPONENTS

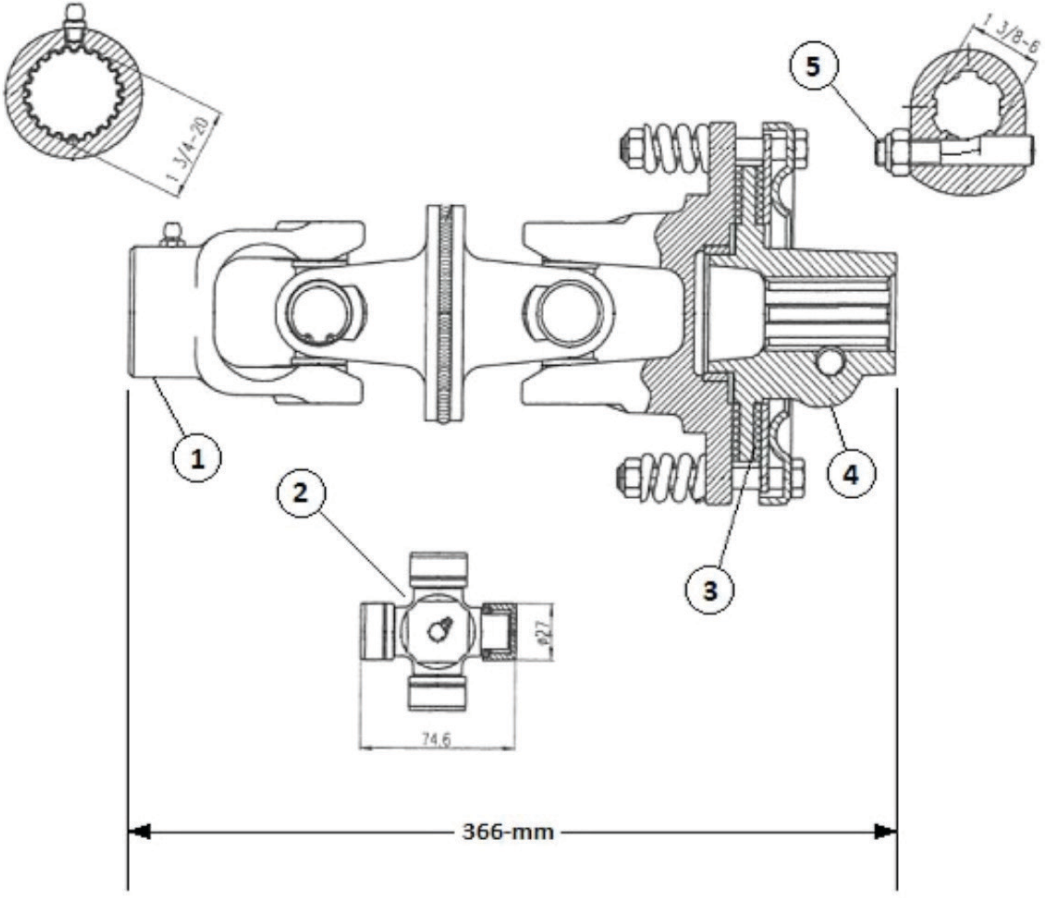

CENTER DECK CROSS SHAFT COMPONENTS			
ITEM	PART #	DESCRIPTION	QTY
1	552070	Gearbox Yoke 1-3/4" 20-Spline	1
2	552071	Cross Kit 27 X 74.6	2
3	552031	Clutch Lining (2-Pack)	1
4	552073	Complete Slipclutch	1
5	552033	Eccentric Pin W/Nut	1
	191203	Complete Cross Shaft	

12.14 C.V. DRIVELINE COMPONENTS

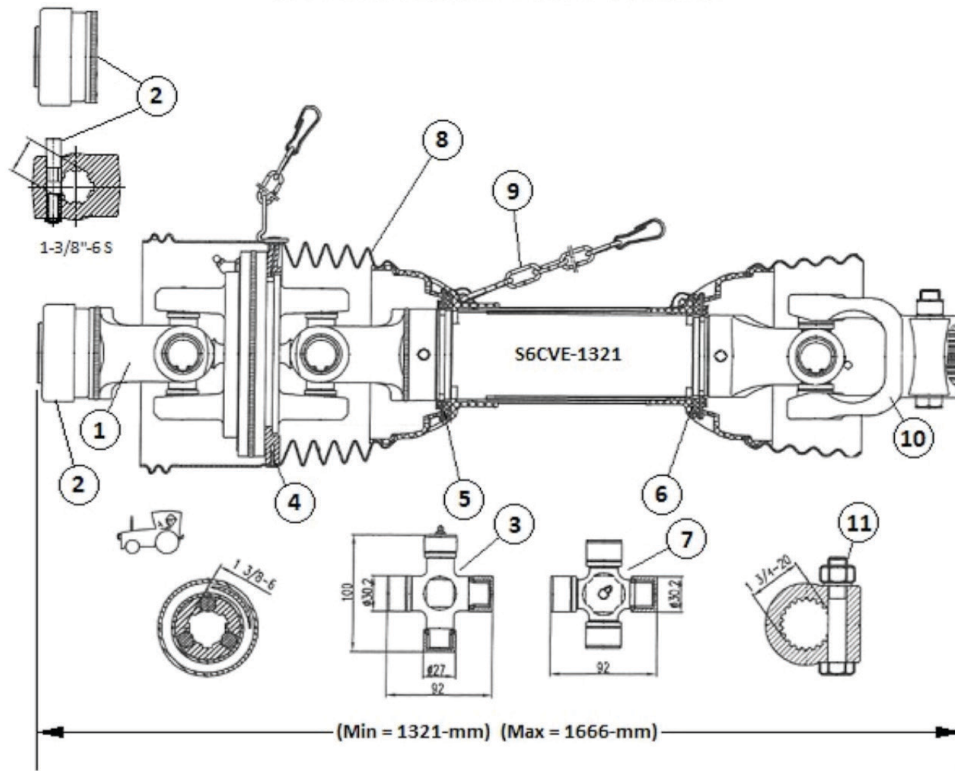

C.V. DRIVELINE COMPONENTS			
ITEM	PART #	DESCRIPTION	QTY
1	552090	Tractor Yoke W/Pull Collar 1-3/8" 6-Spline	1
2	552091	Pull Collar Kit	A/R
or	552051	Push Pin Kit	A/R
3	552052	Cross Kit 27/100 X 30.2/100	2
4	552053	Fixed Ring For C.v. Shield	1
5	552028	Outer Plastic Shield Bearing	1
6	552029	Inner Plastic Shield Bearing	1
7	552056	Cross Kit 30.2 X 92	1
8	552097	Complete Safety Shield	1
9	552005	Safety Chain	3
10	552098	Yoke 1-3/4" 20-Spline	1
11	552162	Lock Bolt W/Nut	1
	191255	Complete C.v. Driveline	

A/R = As Required

12.15 WING DRIVELINE COMPONENTS

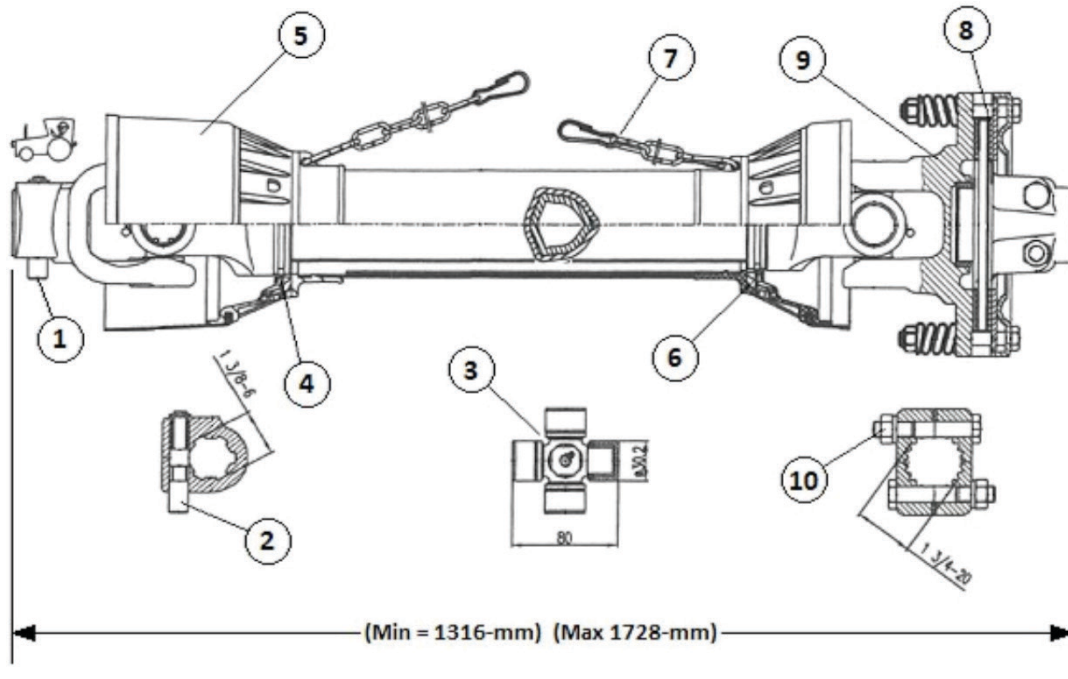

WING DRIVELINE COMPONENTS			
ITEM	PART #	DESCRIPTION	QTY
1	552075	Tractor Yoke 1-3/8" W/Push Pin	1
2	552001	Push Pin Kit	1
3	552048	Cross Kit 30.2 X 80	2
4	552028	Outer Plastic Shield Bearing	1
5	552079	Complete Safety Shield	1
6	552029	Inner Plastic Shield Bearing	1
7	552005	Safety Chain	2
8	552025	Clutch Lining (2-Pack)	1
9	552083	Complete Slipclutch	1
10	552084	Lock Bolt Kit	1
	191254	Complete Wing Driveline	



7 ROCKY MT RD
Athens, Tennessee 37303



(P) 423-405-5150

(F) 423-405-5904

WWW.IRONCRAFTUSA.COM



Revised March 9, 2024
©2023 IronCraft Attachments. All rights reserved.